

Inhalt Contents Contenu

Inhoud Contenido Conteúdo

Einzelteilübersicht / Spare parts list / Liste des pièces détachées /
Onderdelenoverzicht / Lista da piezas / Resumo de peça individual 1

Montagehilfen und Hinweise / Assembly aids and instructions / Aides de montage et instructions /
Montagehulpmiddelen en aanwijzingen / Ayudas de montaje e instrucciones / Montagens e indicações 2

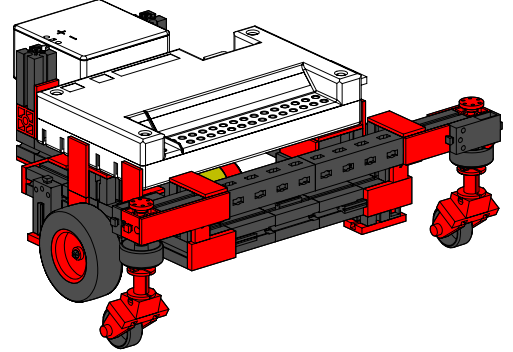
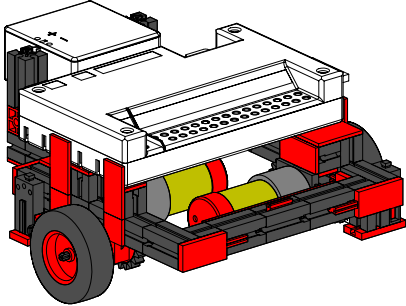

Basismodell / Basic Model / Maquette de base /
Basismodel / Modelo básico / Modelo básico 4

Roboter mit Kantenerkennung / Robot with
Edge Detection / Robot avec détection des
bords / Robots met kantherkenning / Robot
con detección de bordes / Robô com
reconhecimento de bordas 10

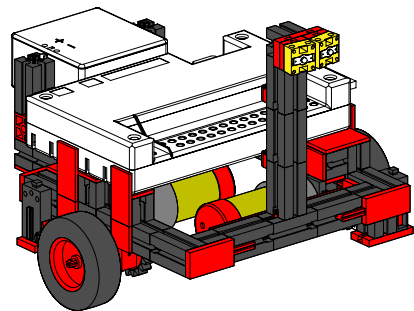
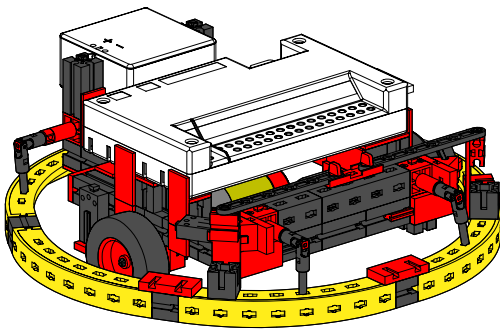

Roboter mit Hinderniserkennung / Robot with
Obstacle Detection / Robot avec détection
des obstacles / Robots met hindernisherkenning /
Robot con detección de obstáculos /
Robô com reconhecimento de obstáculos 18

Lichtsucher / Light Finder /
Chercheur de lumière / Lichtzoeker /
Detector de luz / Identificador de luz 22

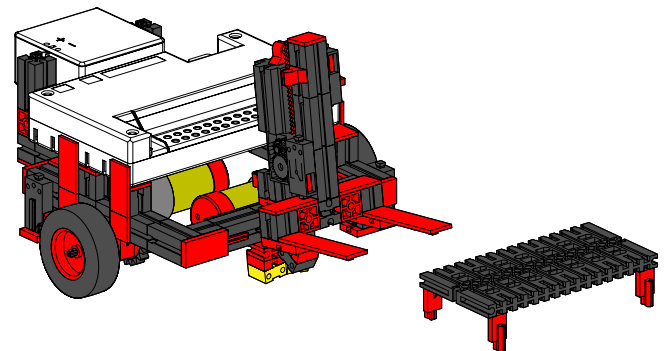
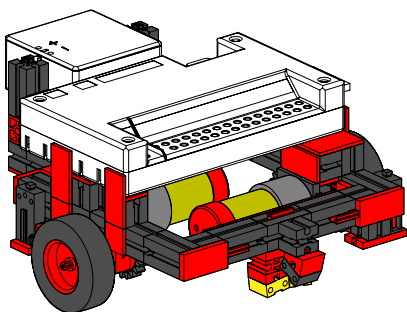









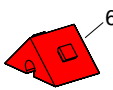
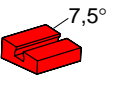

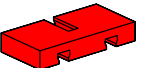

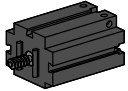
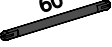

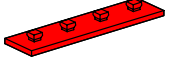



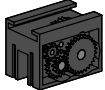

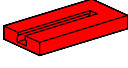
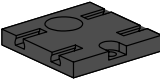
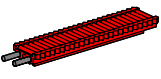



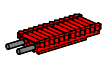

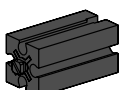

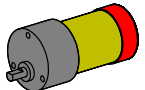





















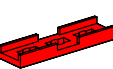

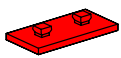

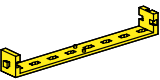
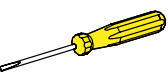
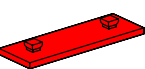



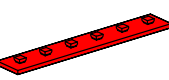

Spurensucher / Tracker / Chercheur de piste /
Sporzoeker / Detector de pistas / Rastreador 24

FTS–Fahrerloses Transportsystem / Driverless
Transport System / FTS–Système de transport sans
chauffeur / FTS–Transportsysteem zonder bestuurder /
FTS–Sistema de transporte sin conductor /
FTS–Sistema de transporte sem condutor 26

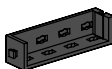
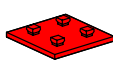
Einzelteilübersicht
Spare parts list
Liste des pièces détachées

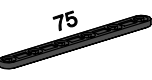
Onderdelenoverzicht
Lista da piezas
Resumo de peça individual

	31010 2x		32071 4x		35064 4x		37157 2x		38428 6x
	31011 8x		32293 1x		35065 2x		37237 4x		38464 2x
	31016 2x		32321 1x		35073 2x		37272 1x		38473 4x
	31021 2x		32330 7x		35090 2x		37351 1x		77312 1x
	31058 2x		32850 2x		35129 1x		37457 1x		78238 2x
	31060 22x		32879 22x		35214 2x		37468 6x		104574 2x
	31061 7x		32881 22x		35945 4x		37679 6x		105195 1x
	31124 3x		32882 7x		35969 4x		37783 6x		105196 2x
	31336 24x		32883 2x		35971 8x		37875 1x		
	31337 24x		32913 2x		35972 4x		38216 1x		
	31597 2x		35031 2x		36134 2x		38240 1x		
	31668 1x		35033 2x		36323 2x		38241 16x		
	31690 2x		35054 6x		36443 1x		38242 2x		
	31848 2x		35055 6x		36574 6x		38245 2x		
	31982 17x		35061 6x		36920 1x		38246 9x		
	31983 4x		35062 2x		36921 2x		38259 2x		
	32064 10x		35063 2x		36923 2x		38423 14x		

Montagehilfen und Hinweise
Assembly aids and instructions
Aides de montage et instructions

Montagehulpmiddelen en aanwijzingen
Ayudas de montaje e instrucciones
Montagens e indicações

Kabel und Stecker
Plugs and cables
Fiches et des câbles

1

4 x 15 cm
8 x 23 cm

0 3cm

2

3cm 3cm

Stekkers en cables
Enchufes en cables
Cabos e contatos

3

4mm

4

4 x 15 cm
8 x 23 cm

1

9 V ...

2

2x

1

2

1

2

4x

Alle elektrischen Bauteile (Sensoren, Motoren, Lampen) dürfen ausschließlich an Stromversorgungen von fischertechnik angeschlossen werden (z.B. Energy Set Art.-Nr. 30182; Accu Set Art.-Nr. 34969).

No electrical components (sensors, motors and lamps) are to be connected to any other power supply than that provided by fischertechnik (e.g. Energy Set, product no. 30182, Accumulator Set, product no. 34969).

Tous les composants électriques (Capteurs, moteurs, lampes) ne doivent être branchés aux alimentations électriques uniquement que par la société Fischertechnik (par exemple: Set énergie Art.-Nr. 30182, Accu Set Art.-Nr. 34969).

Alle elektrische componenten (sensoren motoren, lampen) mogen uitsluitend op stroomvoorzieningen van fischertechnik worden aangesloten. (bijv. Energy Set art.nr. 30182, Accu Set art.nr. 34969).

Todos los componentes eléctricos (sensores, motores, luces) deben conectarse a la alimentación de corriente de la técnica Fischer exclusivamente (p.ej. Energy Set Art.-Nº. 30182, Accu Set Art.-Nº. 34969).

Todas as peças componentes elétricas (sensores, motores, lâmpadas) só podem ser exclusivamente conectadas em abastecimentos de corrente da Fischertechnik (p.ex. Energy Set Nº de prod. 30182, Accu Set Nº de prod. 34969).

■ Alle Einzelteile, insbesondere bewegliche Teile sind falls notwendig zu warten und zu reinigen.

■ All components, especially moving parts, should be maintained and cleaned as necessary.

■ Toutes les pièces détachées et en particulier les pièces mobiles, sont, si nécessaire, à entretenir et à nettoyer.

■ Achtung
Verletzungsgefahr an Bauteilen mit funktionsbedingten scharfen Kanten und Spitzen!

■ Caution
Be careful not to hurt yourself on components with sharp or pointed edges!

■ Attention
Risque de blessure sur les éléments comportant des arêtes et o pointes vives indispensables au bon fonctionnement!

■ Alle onderdelen, vooral de bewegende delen, kunnen, indien noodzakelijk, onderhouden en gereinigd worden.

■ Es necesario limpiar y mantener en buen estado todas las diferentes piezas – especialmente las piezas móviles.

■ Caso necessário, todas as peças individuais, especialmente peças móveis, tem que ser submetidas à manutenção e ser limpadas.

■ Let op
U kunt zich bezeren aan bouwstenen met scherpe randen of punten!

■ Attenzione
Esiste il pericolo di lesione con i pezzi di costruzione che hanno bordi e punte spigolosi necessari per la funzionalità del pezzo!

■ Atenção
Perigo de ferimentos em peças componentes com cantos vivos e pontas obrigatórios para o funcionamento !

Montagehilfen und Hinweise
Assembly aids and instructions
Aides de montage et instructions

Montagehulpmiddelen en aanwijzingen
Ayudas de montaje e instrucciones
Montagens e indicações

Fototransistor
 Phototransistor
 Phototransistor

Fototransistor
 Fototransistores
 Fototransistor

Achtung: Beim Anschluß auf richtige Polung achten. Rot = +
 Caution: Make sure the terminals are connected correctly. Red = +
 Attention: lors du raccordement, veiller à ce que la polarisation soit exacte, rouge = +
 Pas op: let bij het aansluiten op de juiste polariteit, rood = +
 Atención: al conectar, procurar que los polos estén correctamente colocados, roja = +
 Atenção: Por ocasião da conexão atentar para a polaridade correta. Vermelho = +



9V ...

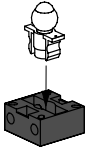

9V ... / 0,15 A

Linsenlampe
 Lens tip lamp
 Ampoule lentille
 Lenslampje
 Lampada lenticolare
 Lâmpada de formato lenticular

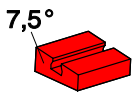
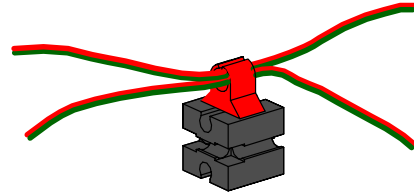

7,5°

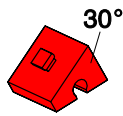

30°

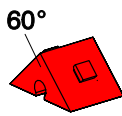

60°



7.5

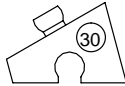

30

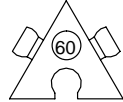

60

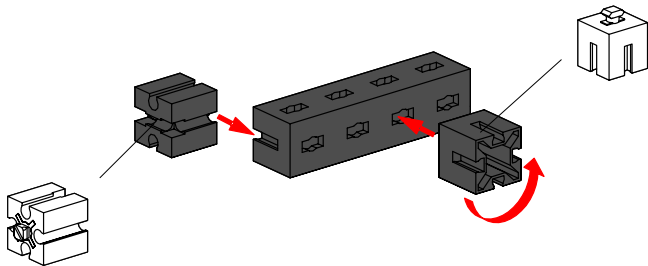
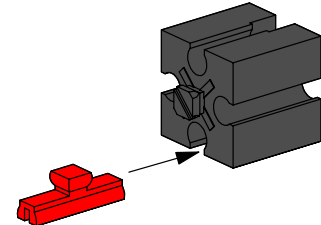
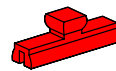
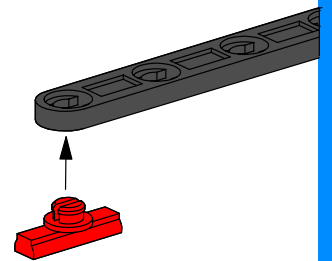
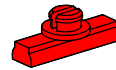

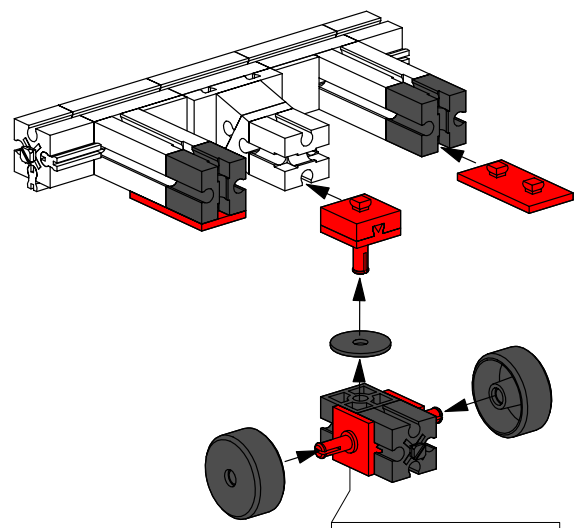
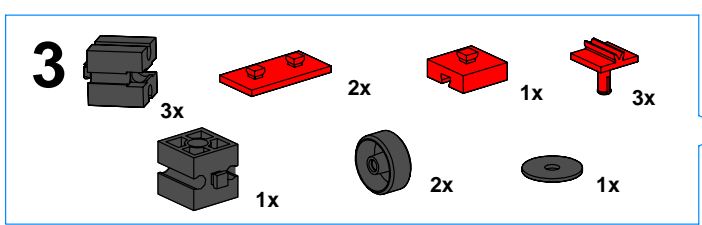
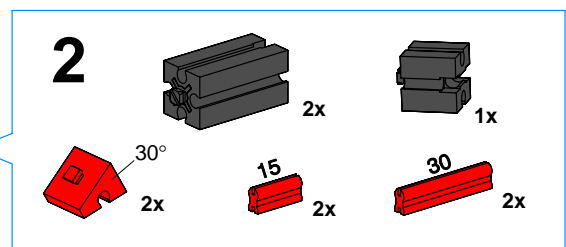
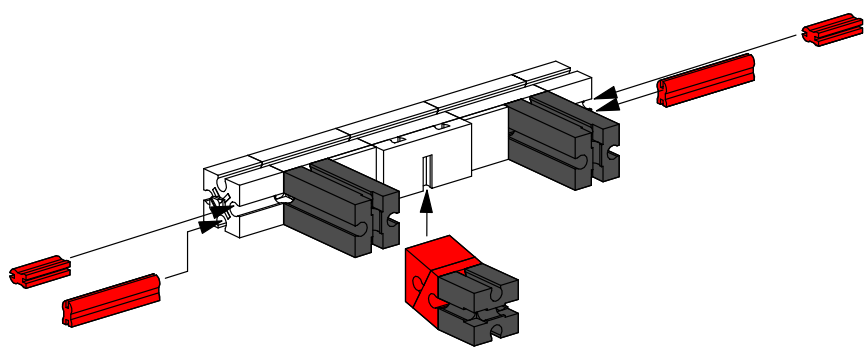
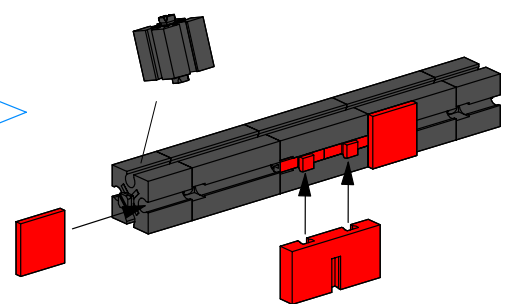
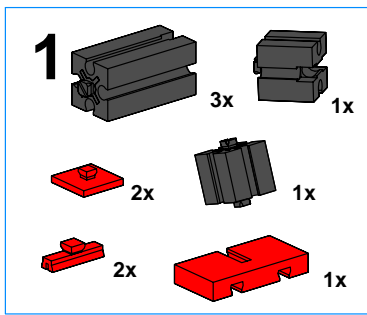
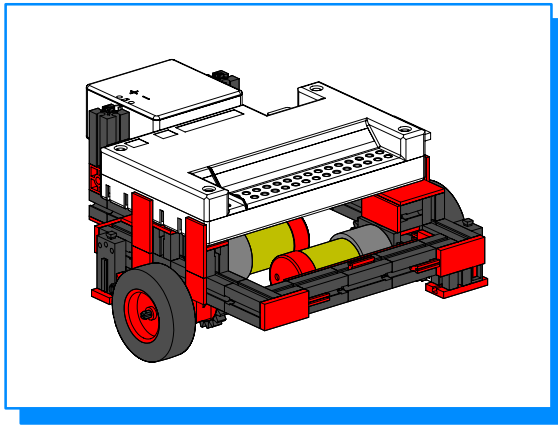

**Basismodell
Basic Model
Maquette de base**

**Basismodel
Modelo básico
Modelo básico**



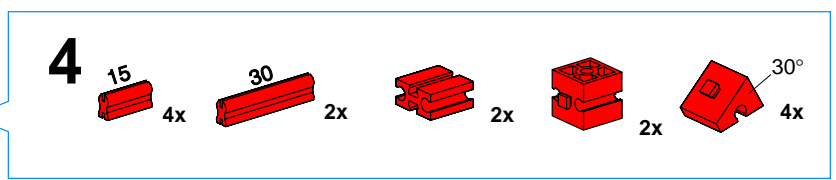
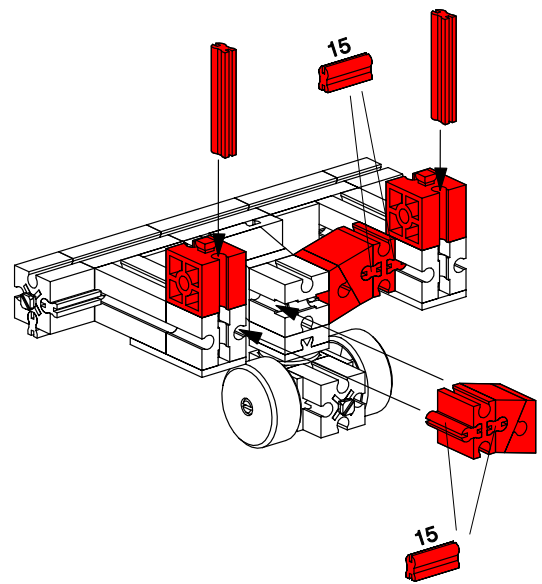

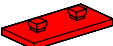
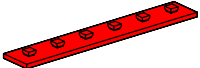
**Große Bohrung
Large drilling
Alésage large
Grote boring
Perforación grande
Orificio grande**



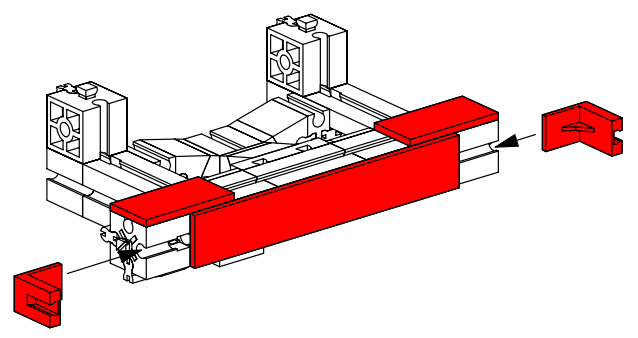
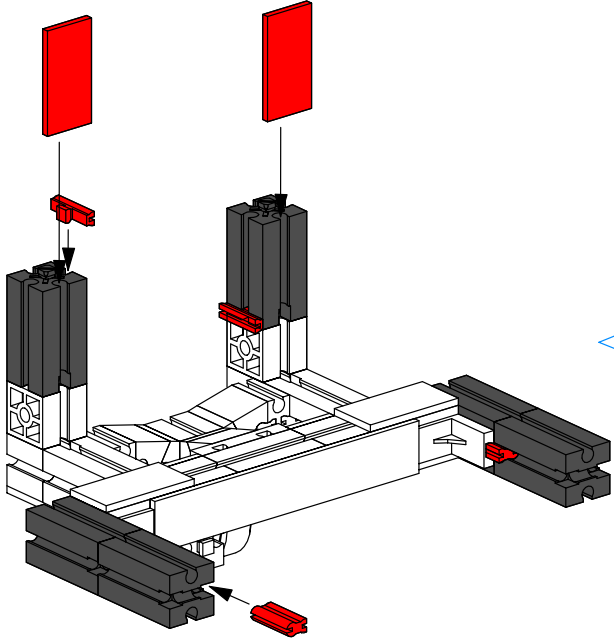

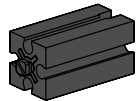

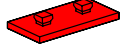

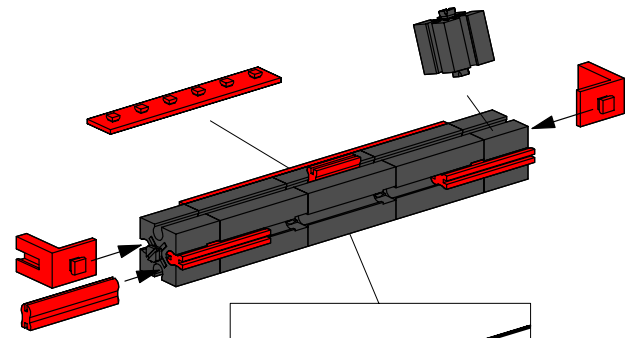
5  2x  1x  2x

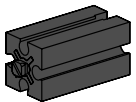



6  6x  2x  2x  2x



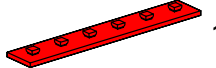

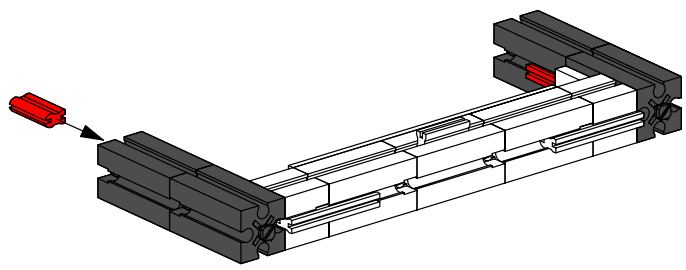
7  3x  1x  1x  2x

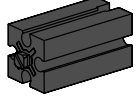

 1x  3x  1x

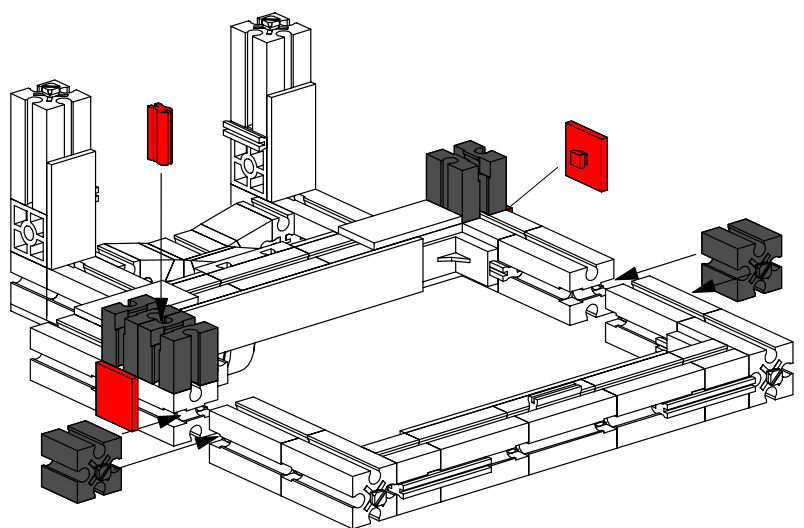

8  4x  1x



9  3x  2x

 1x  2x

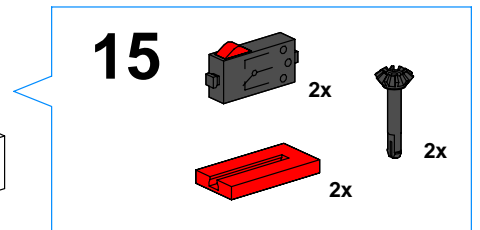
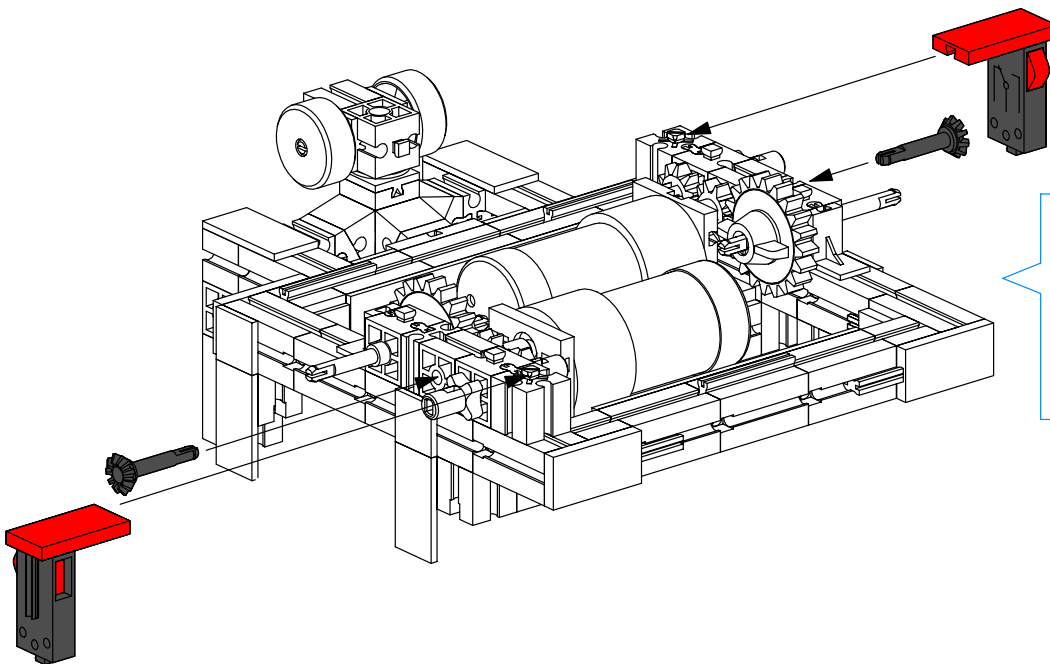
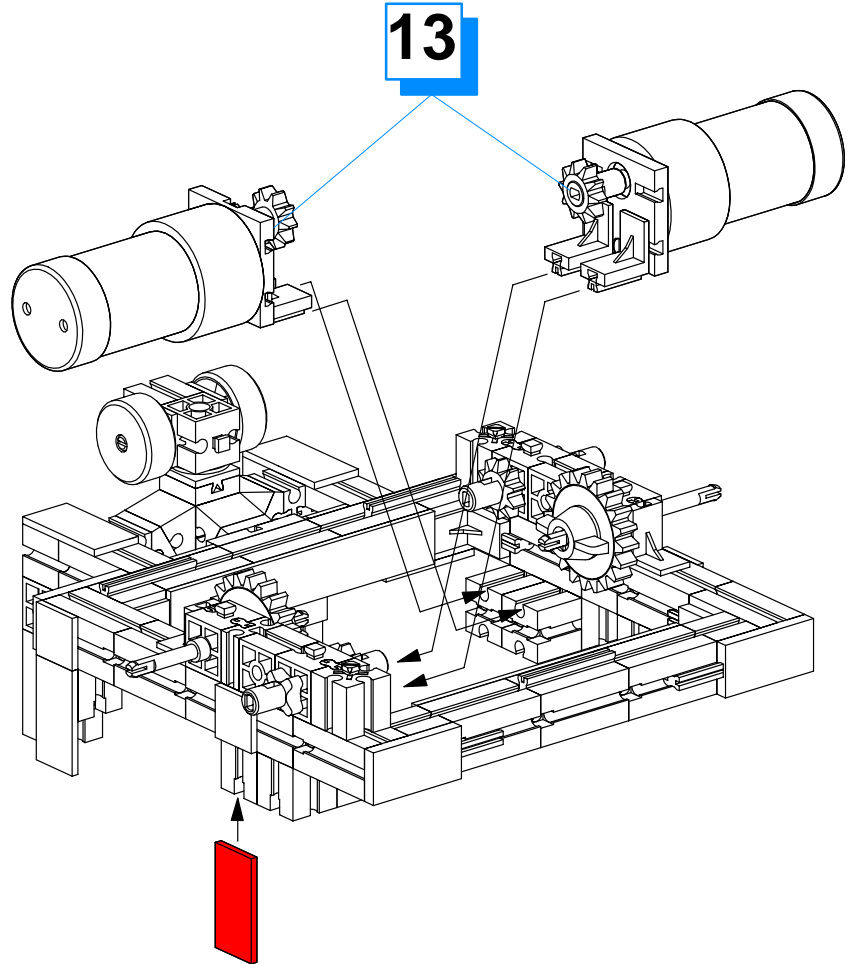
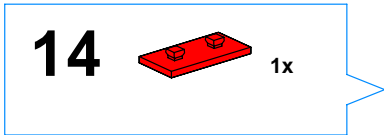
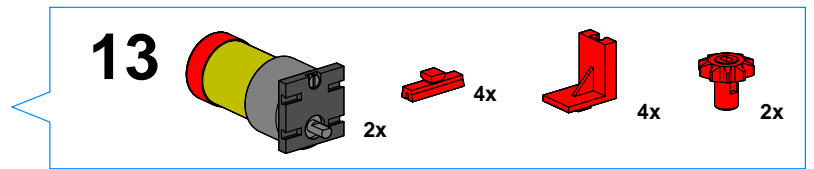
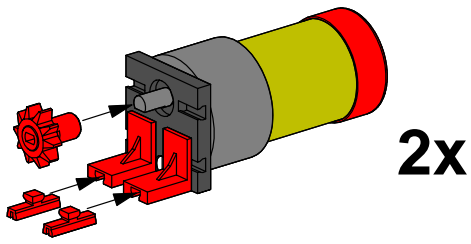

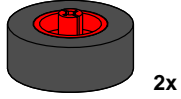
16

2x



2x

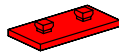

3x



2x



2x



2x

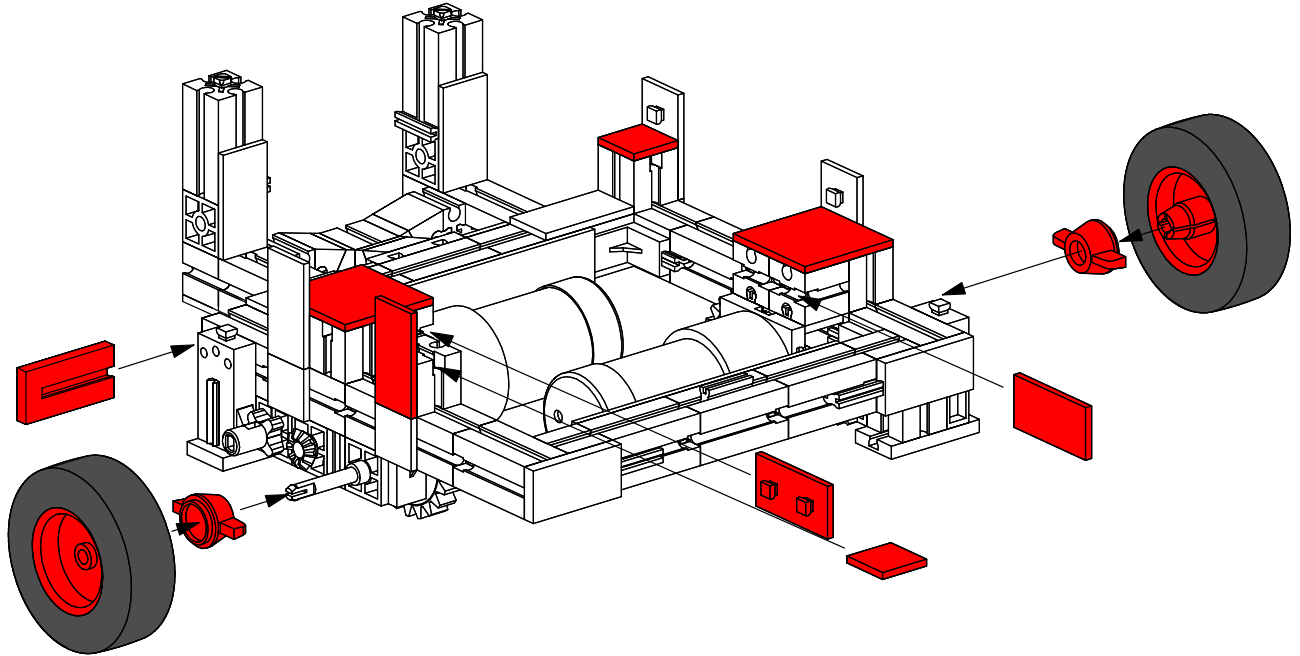

- Intelligent Interface (Art.-Nr. 30402) nicht im Baukasten enthalten
- Intelligent interface (Art. No. 30402) not included in the modular kit
- L'interface intelligente (réf. 30402) n'est pas contenue dans le kit
- Intelligent Interface (art.-nr. 30402) niet in de bouwdoos opgenomen
- El Intelligent Interface (art. n° 30402) no está incluido en el conjunto
- Intelligent Interface (N° de prod. 30402) não contido no sistema de construção por blocos

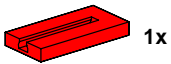
17

1x



1x

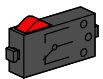

1x



1x

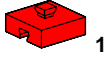

1x

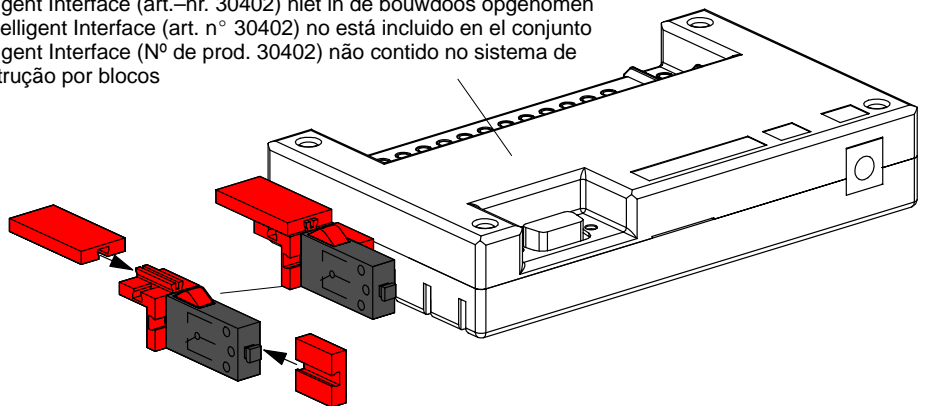

- Accu Set (Art.-Nr. 34969) nicht im Baukasten enthalten
- Accu Set (Art. No. 34969) not included in the modular kit
- Accu Set (réf. 34969) n'est pas contenue dans le kit
- Accu Set (art.-nr. 34969) niet in de bouwdoos opgenomen
- Accu Set (art. n° 34969) no está incluido en el conjunto
- Accu Set (Nº de prod. 34969) não contido no sistema de construção por blocos

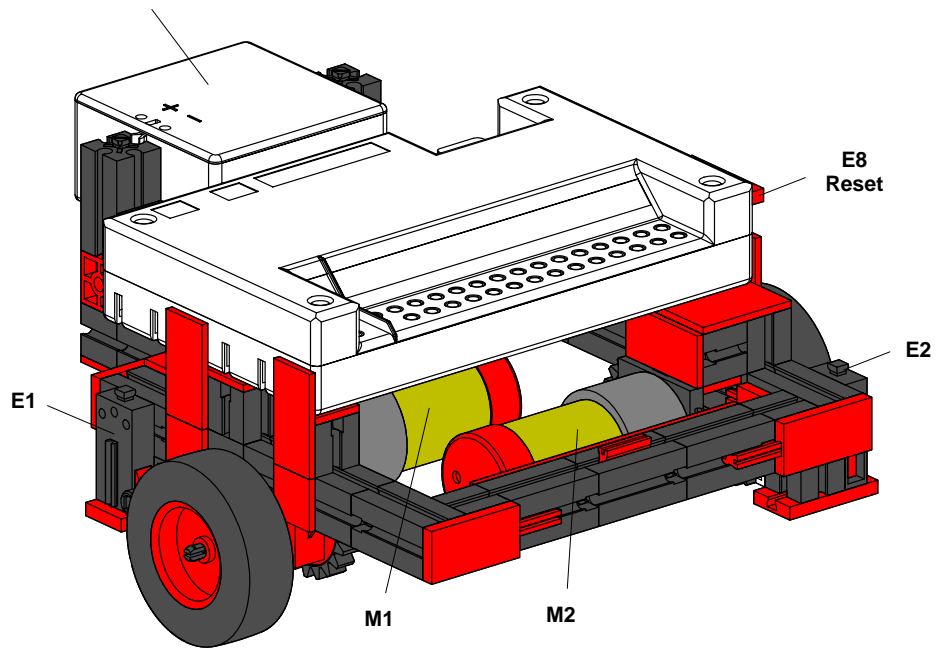

Elektrischer Schaltplan
Circuit diagram
Plan électrique

Schakelschema
Diagrama de circuitos
Plano elétrico de ligação

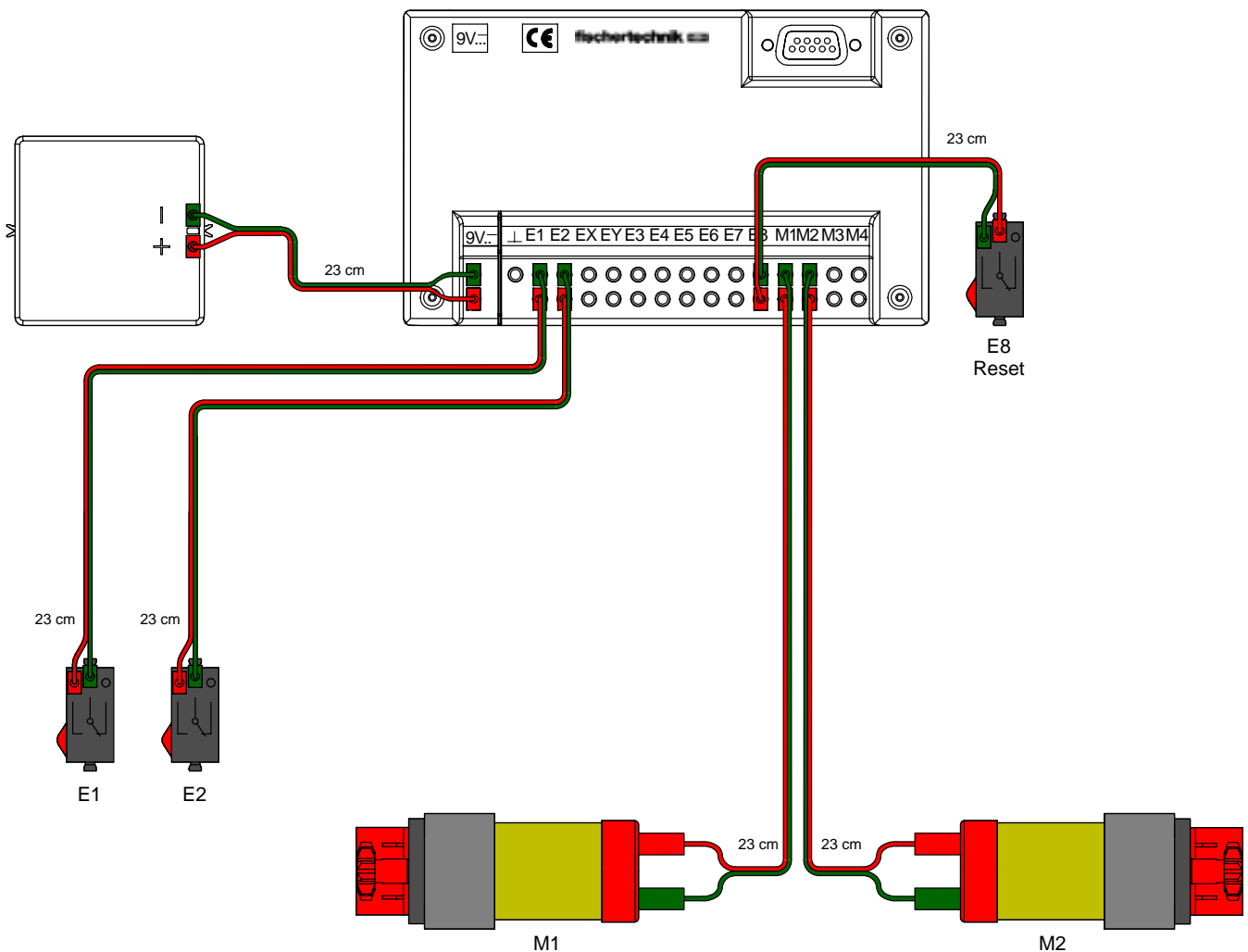

Roboter mit Kantenerkennung
 Robot with Edge Detection
 Robot avec détection des bords

Robots met kantherkenning
 Robot con detección de bordes
 Robô com reconhecimento de bordas

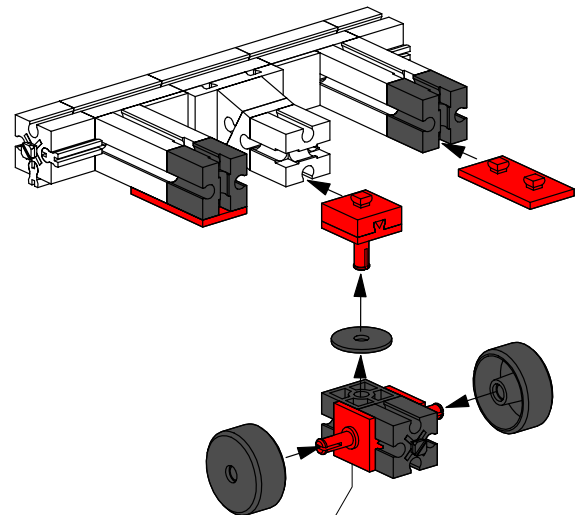
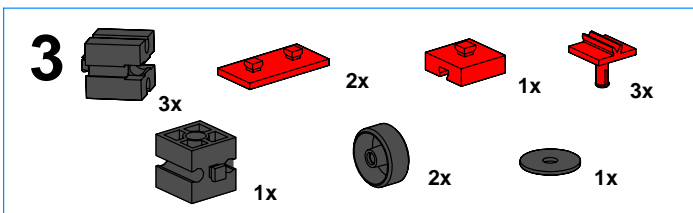
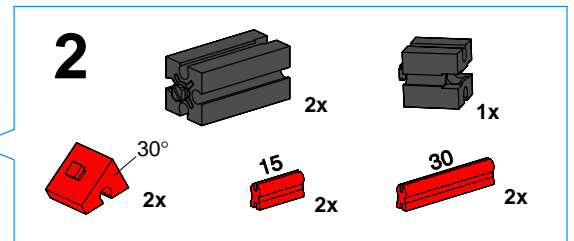
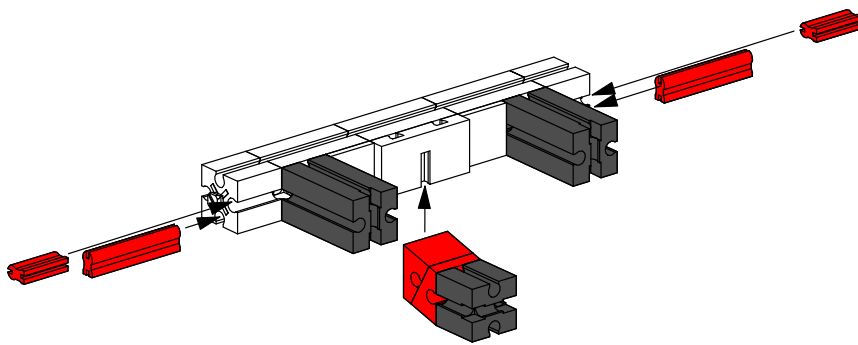
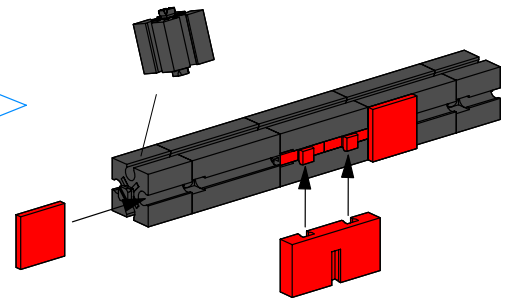
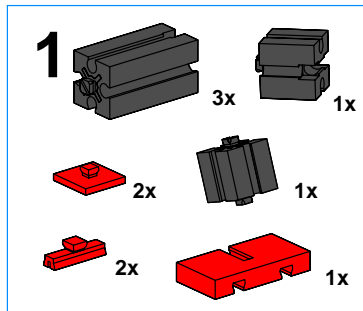
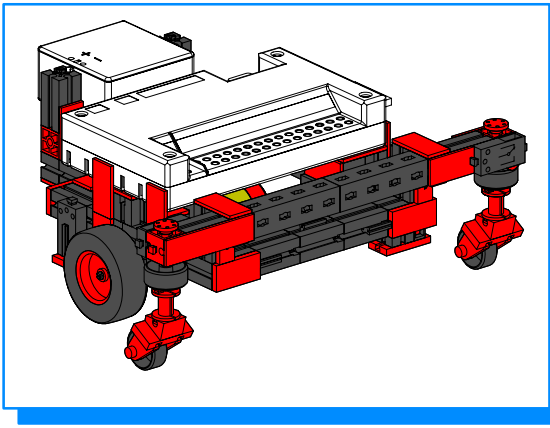

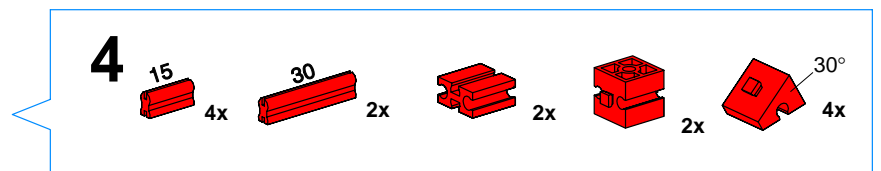
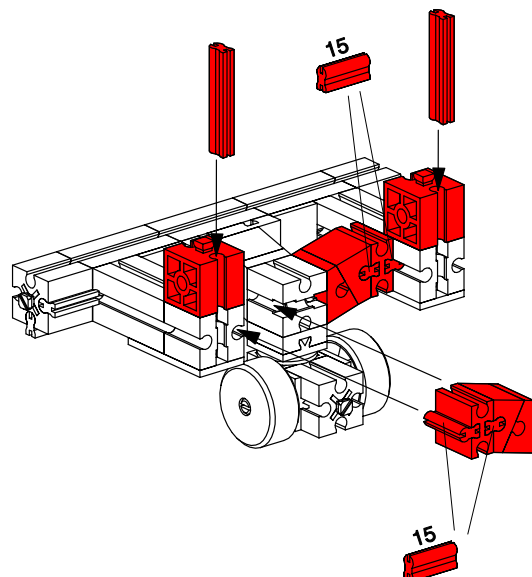

 Große Bohrung
 Large drilling
 Alésage large
 Grote boring
 Perforación grande
 Orificio grande

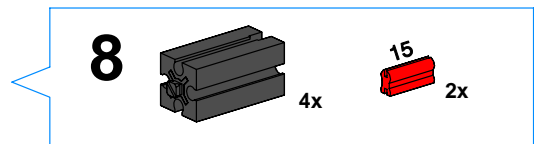
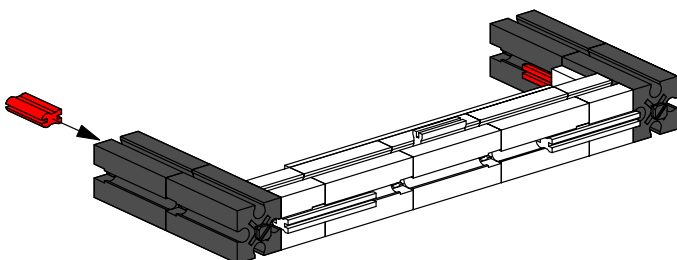
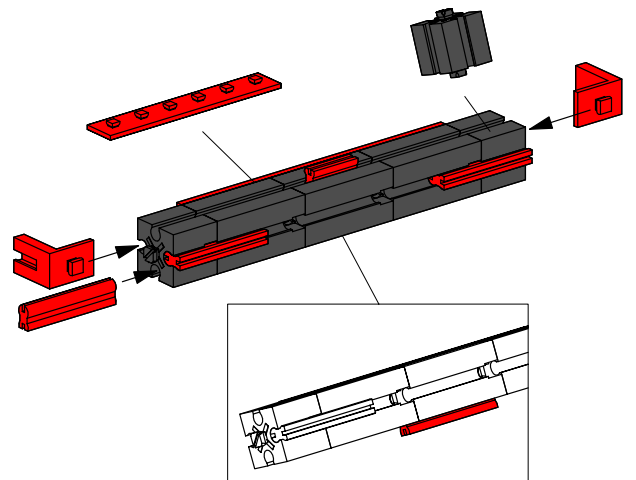
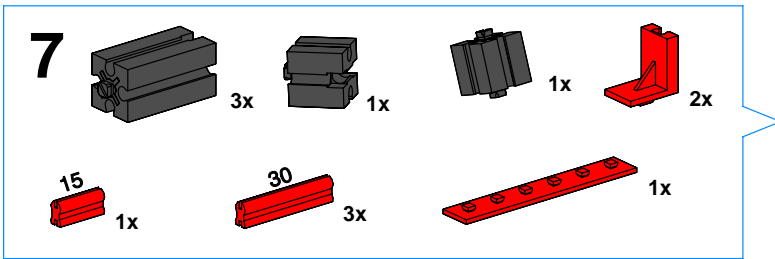
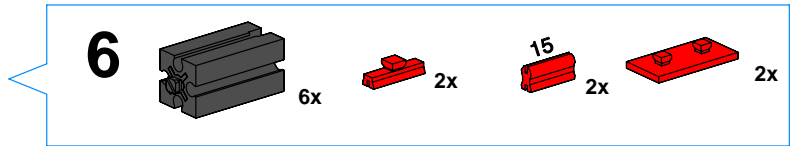
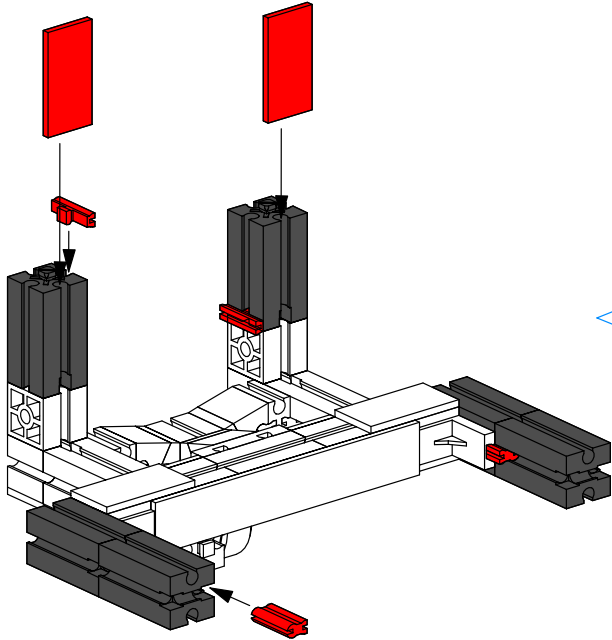
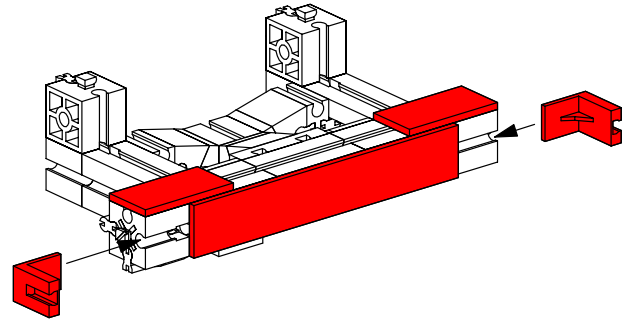
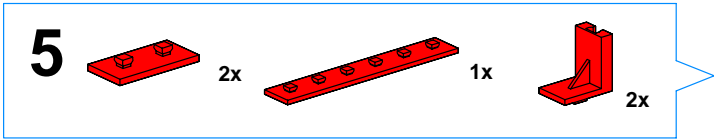

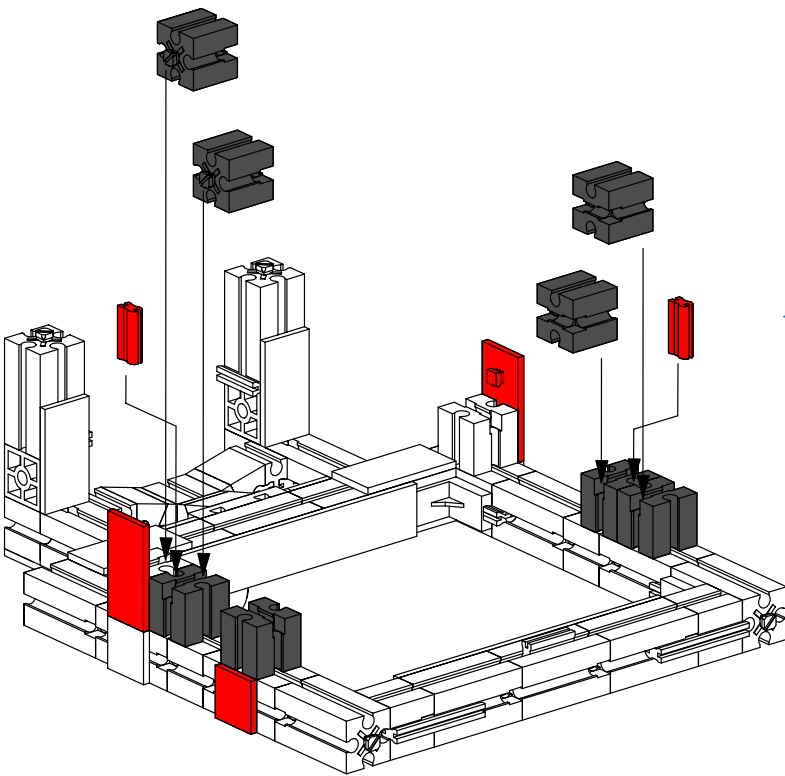
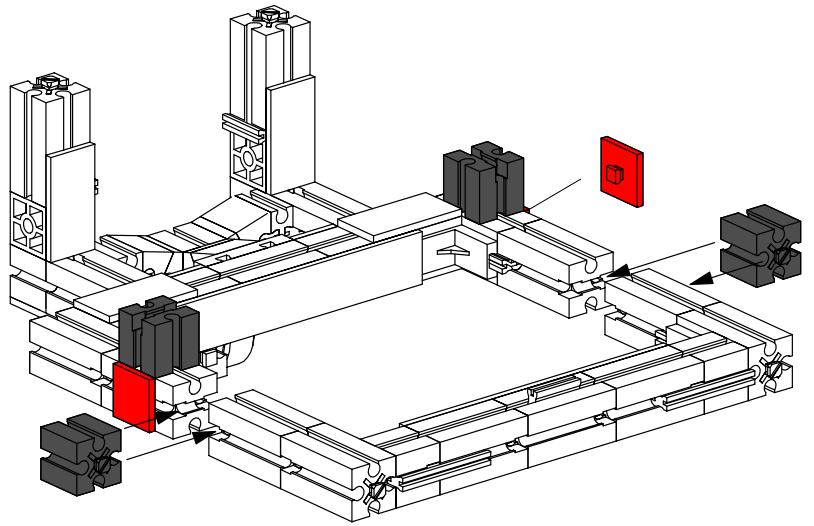

9

- 2x [Grey 2x3 Technic Brick]
- 2x [Grey 2x3 Technic Brick with Groove]
- 2x [Red 1x2 Technic Plate]



10

- 8x [Grey 2x3 Technic Brick]
- 2x [Red 1x5 Technic Plate]
- 2x [Red 1x2 Technic Plate]
- 1x [Red 1x2 Technic Plate]

11

- 4x [Red 2x3 Technic Brick]
- 2x [Grey 2x3 Technic Brick with Groove]
- 2x [Red 1x3 Technic Plate with Groove]
- 1x [Red 1x2 Technic Plate]
- 2x [Grey 30mm Technic Pin]
- 2x [Grey Technic Axle with Friction Ridge]
- 2x [Grey Technic Axle with Friction Ridge]
- 2x [Red 1x5 Technic Plate]
- 2x [Red 1x3 Technic Plate with Groove]

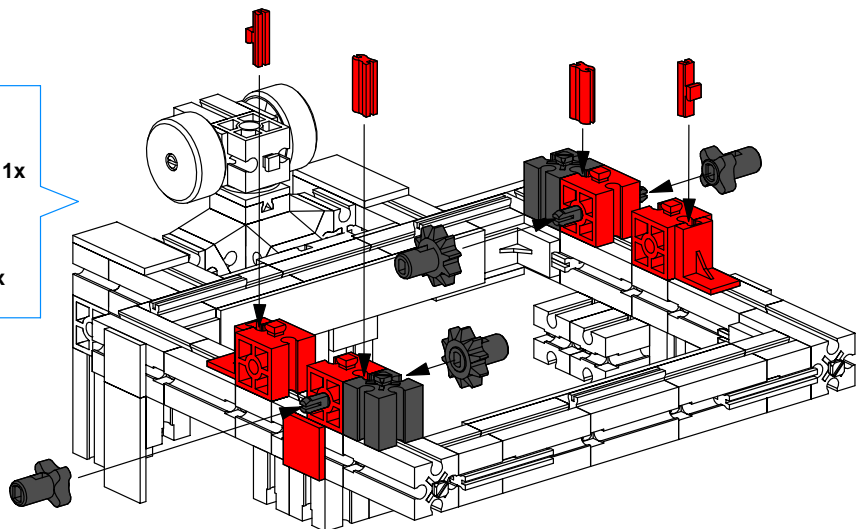
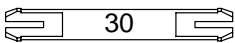

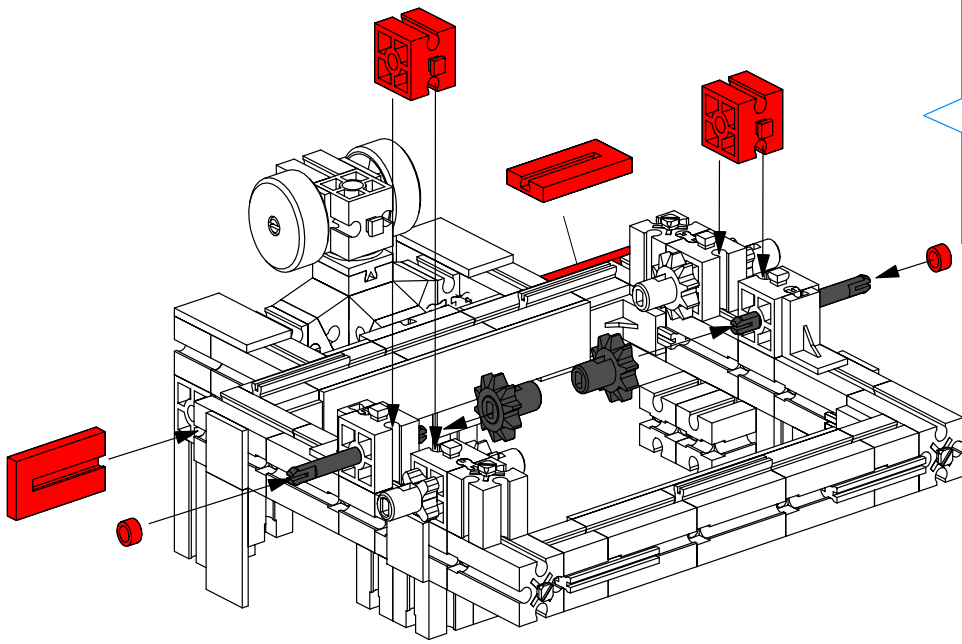

12

- Red 2x3 Technic Brick with Hole: 2x
- Red 1x3 Technic Beam: 2x
- Grey Technic Pin: 2x
- Grey Technic Gear: 2x
- Red Technic Pin: 2x

45

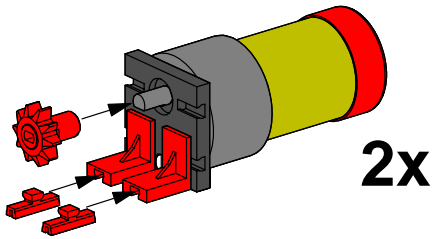

13

- Motor with Gear Housing: 2x
- Red 1x2 Technic Beam: 4x
- Red 1x3 Technic Beam with Hole: 4x
- Red Technic Gear: 2x

13

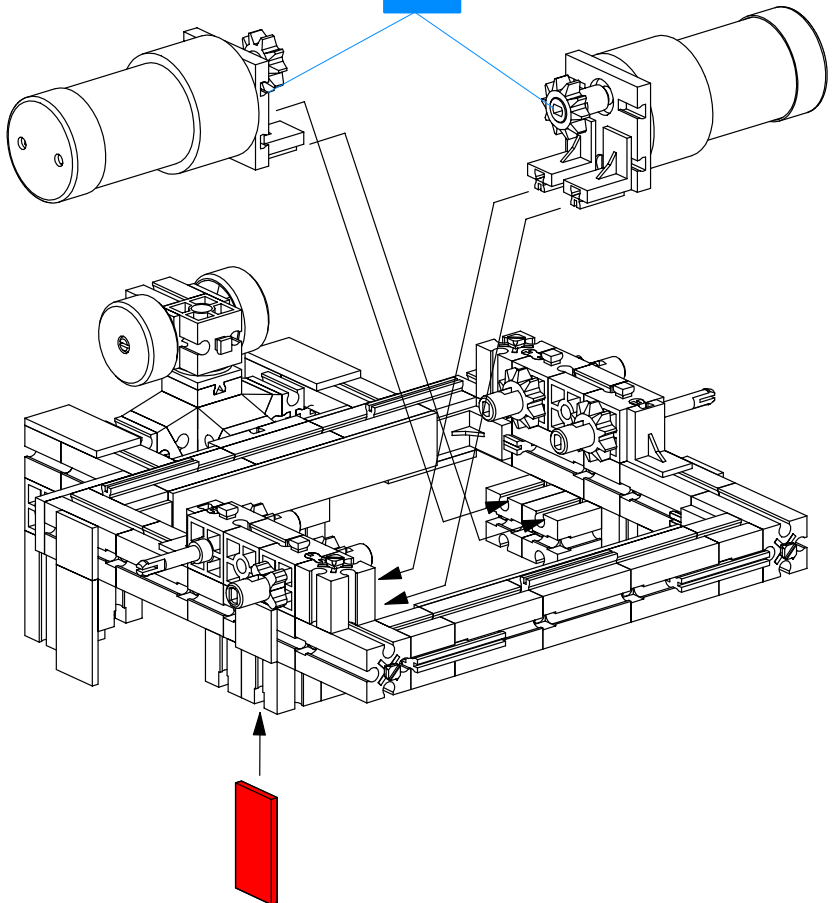

14

- Red 1x3 Technic Beam: 1x

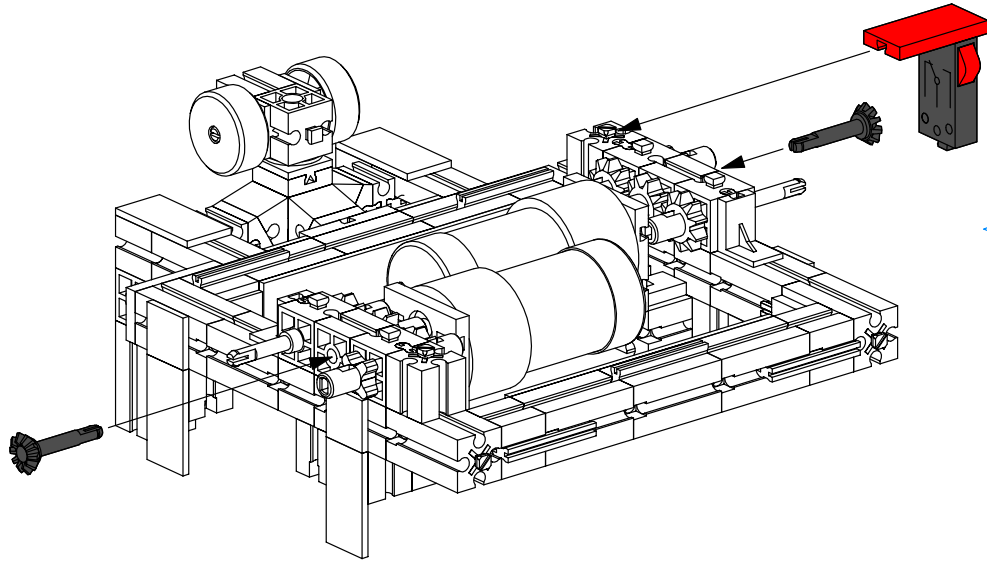

15

- Black Technic axle with a gear: 2x
- Red Technic brick with notch: 1x
- Black Technic axle with a pulley: 1x

16

- Black Technic axle with a pulley: 2x
- Red Technic axle with a pulley: 2x
- Red Technic 1x3 brick: 3x
- Red Technic 1x2 brick: 2x
- Red Technic 1x4 brick with 4 holes: 2x

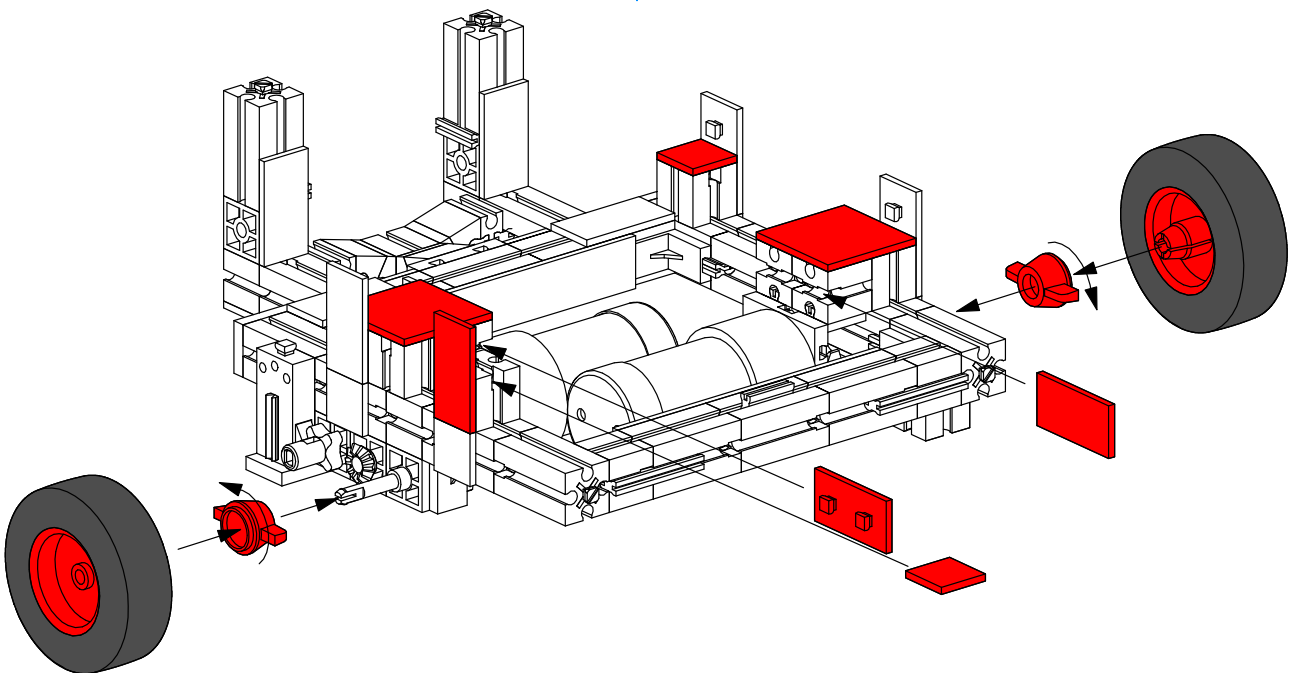

17

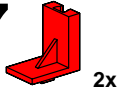

2x

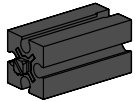

2x

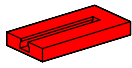

2x



15

2x

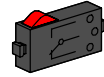

1x

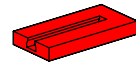

3x

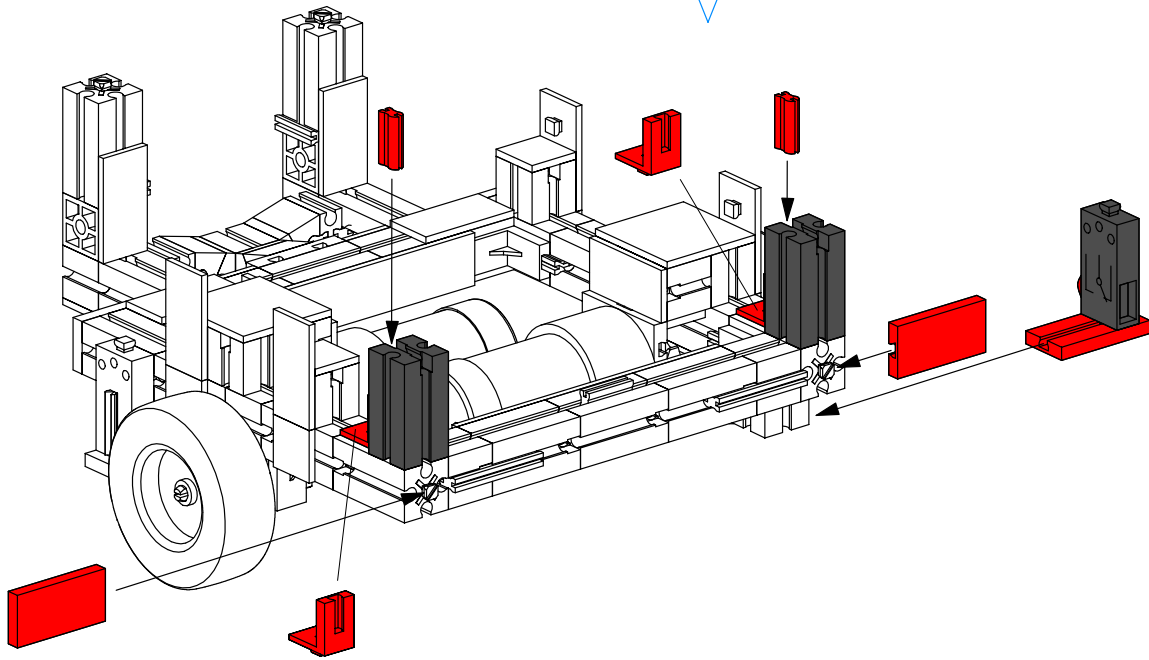

18



2x

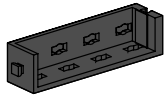

2x



3x



2x

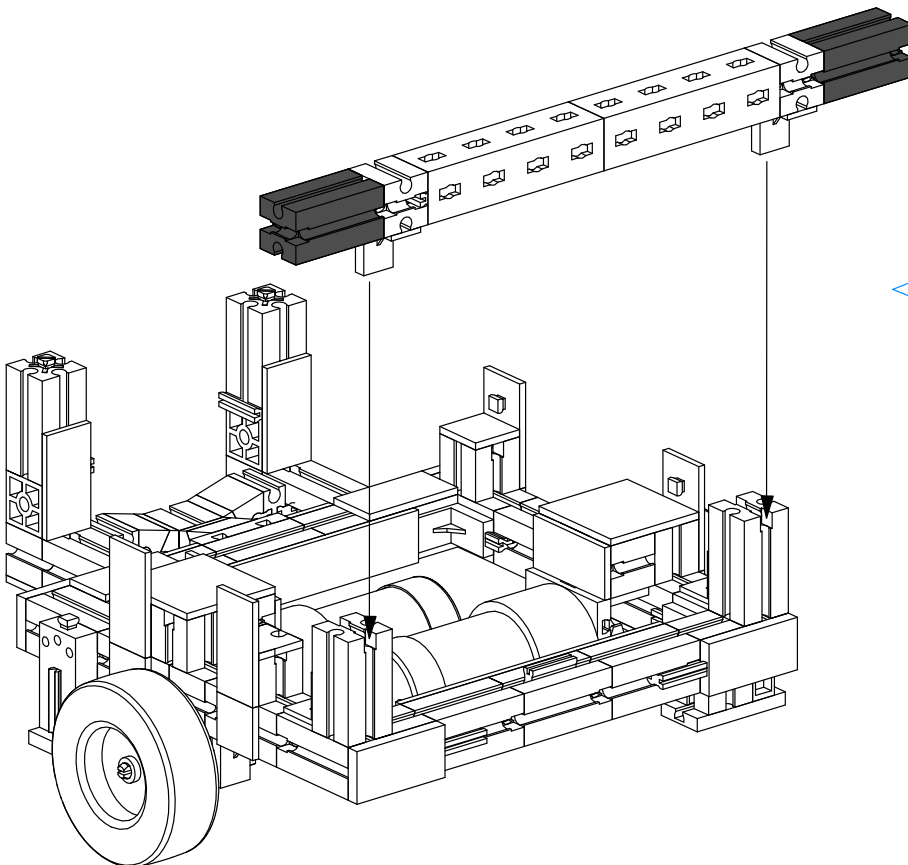
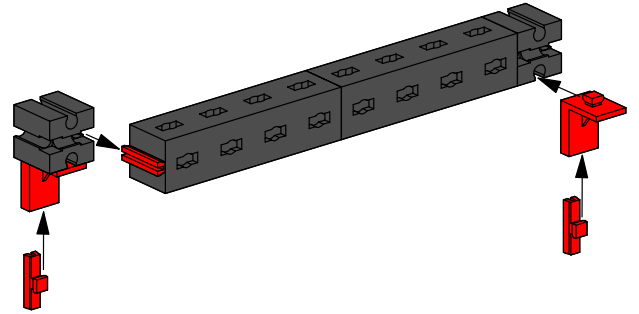

19

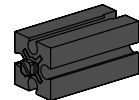

2x

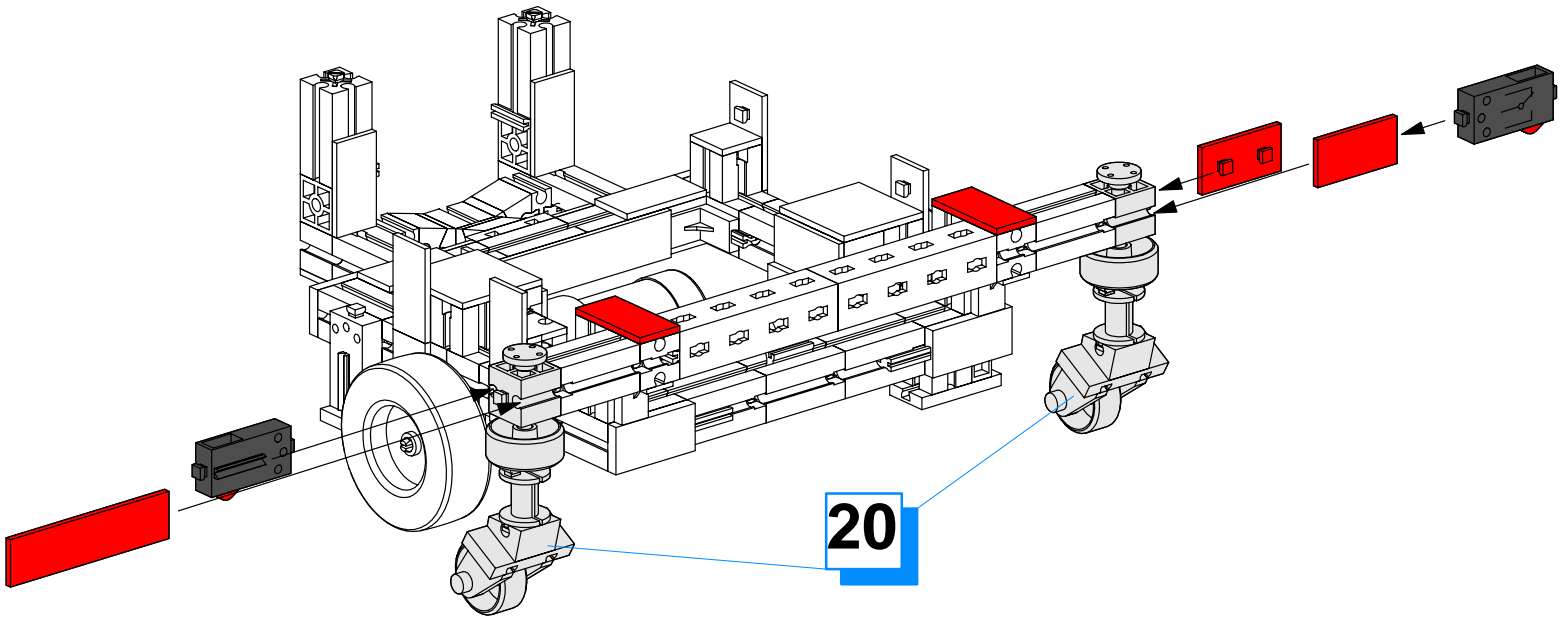
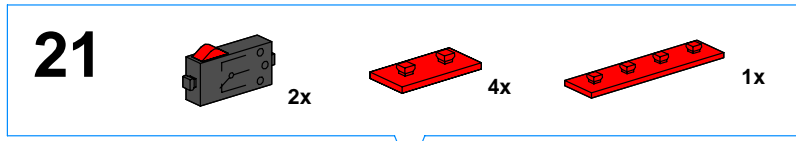
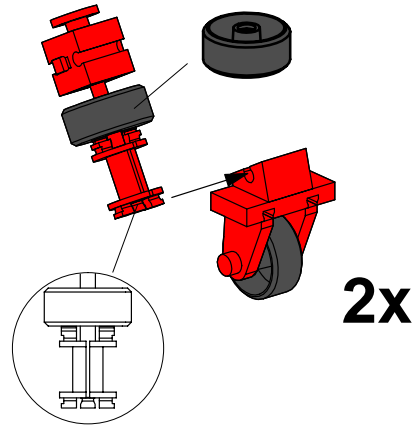
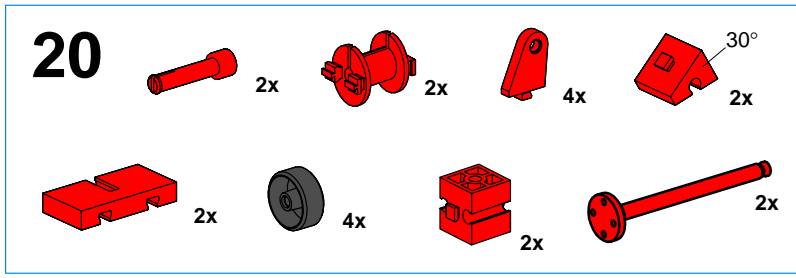

- Intelligent Interface (Art.-Nr. 30402) nicht im Baukasten enthalten
- Intelligent interface (Art. No. 30402) not included in the modular kit
- L'interface intelligente (réf. 30402) n'est pas contenue dans le kit
- Intelligent Interface (art.-nr. 30402) niet in de bouwdoos opgenomen
- El Intelligent Interface (art. n.º 30402) no está incluido en el conjunto
- Intelligent Interface (Nº de prod. 30402) não contido no sistema de construção por blocos

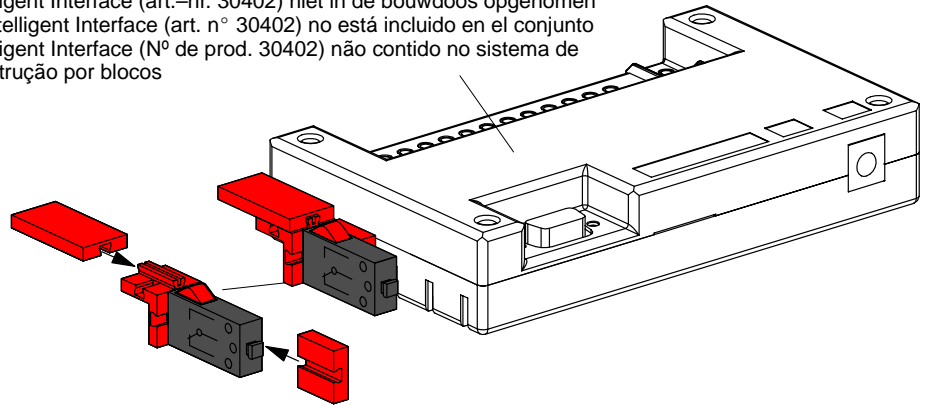
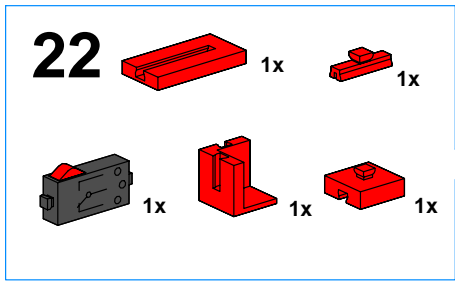

- Accu Set (Art.-Nr. 34969) nicht im Baukasten enthalten
- Accu Set (Art. No. 34969) not included in the modular kit
- Accu Set (réf. 34969) n'est pas contenue dans le kit
- Accu Set (art.-nr. 34969) niet in de bouwdoos opgenomen
- Accu Set (art. n° 34969) no está incluido en el conjunto
- Accu Set (Nº de prod. 34969) não contido no sistema de construção por blocos

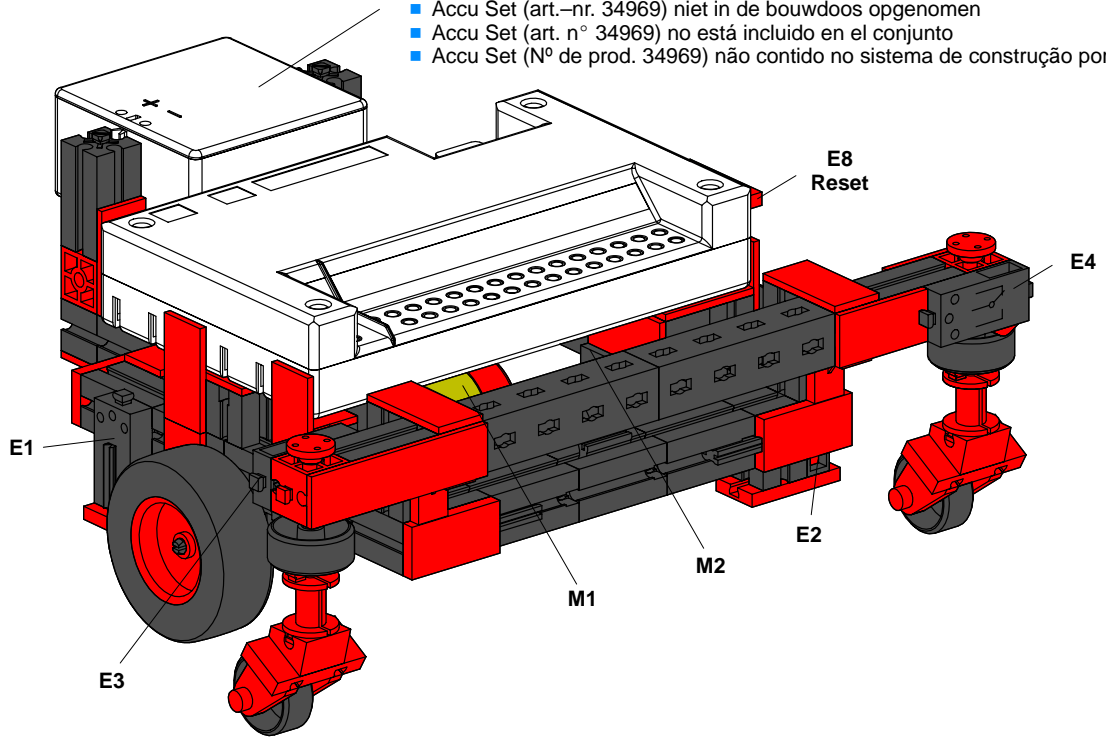

Elektrischer Schaltplan
Circuit diagram
Plan électrique

Schakelschema
Diagrama de circuitos
Plano elétrico de ligação

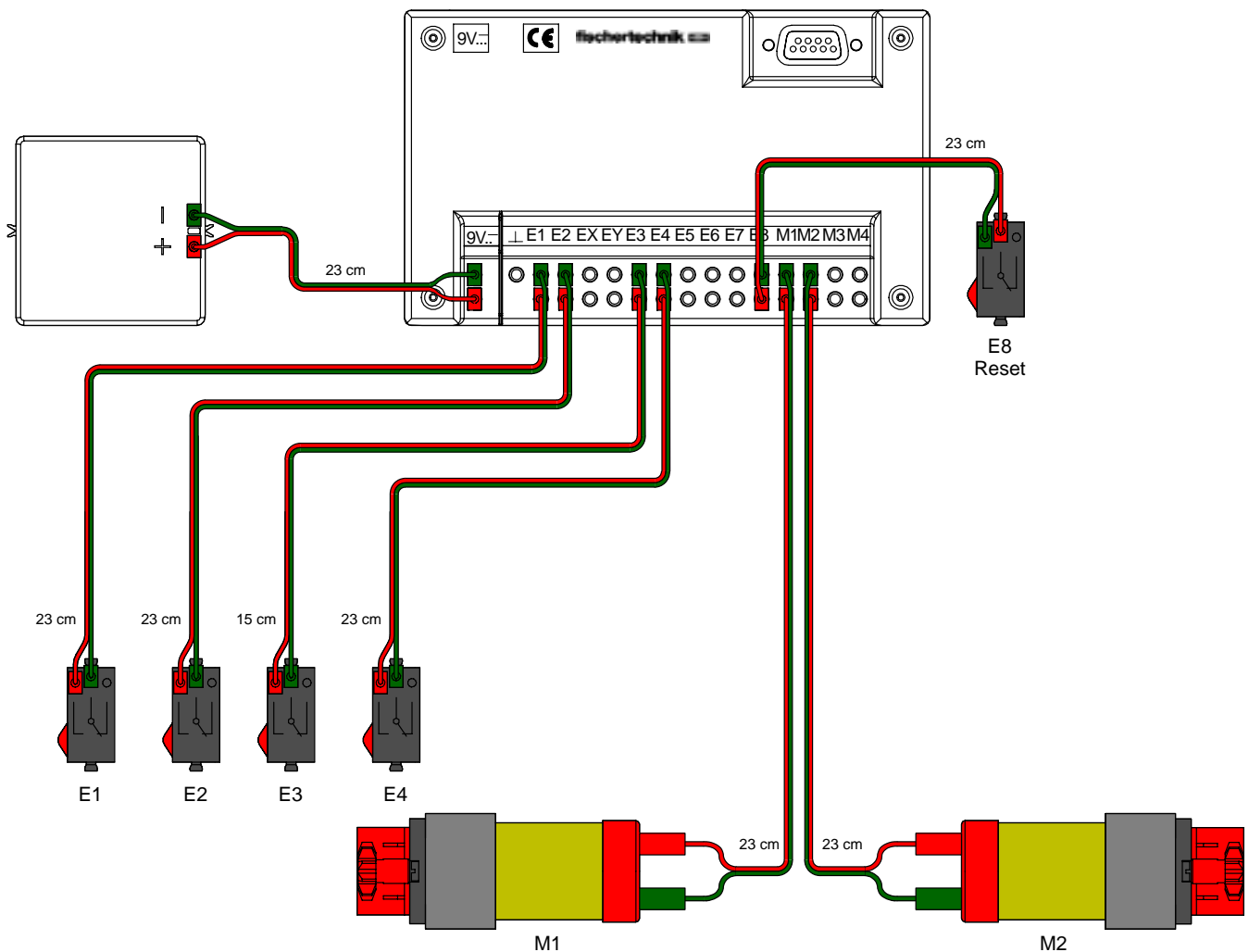

1 – 16

Seite	10
Page	10
Page	10
Bladzijde	10
Página	10
Pagina	10

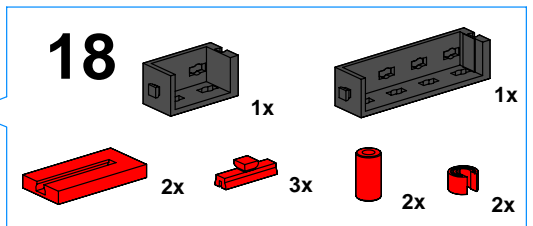
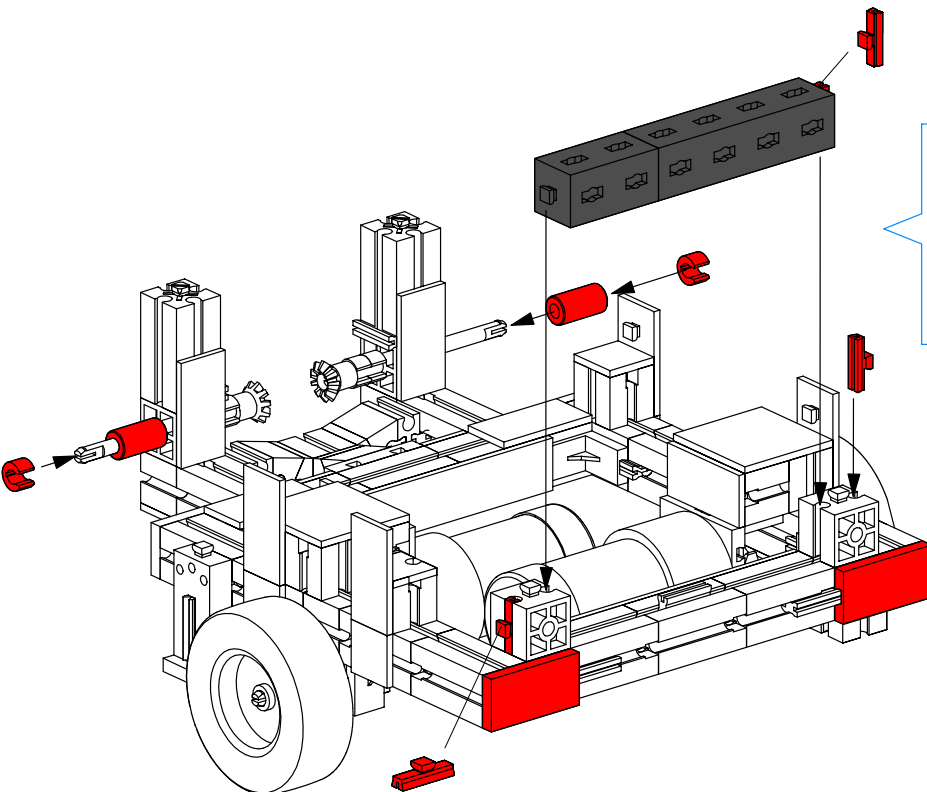
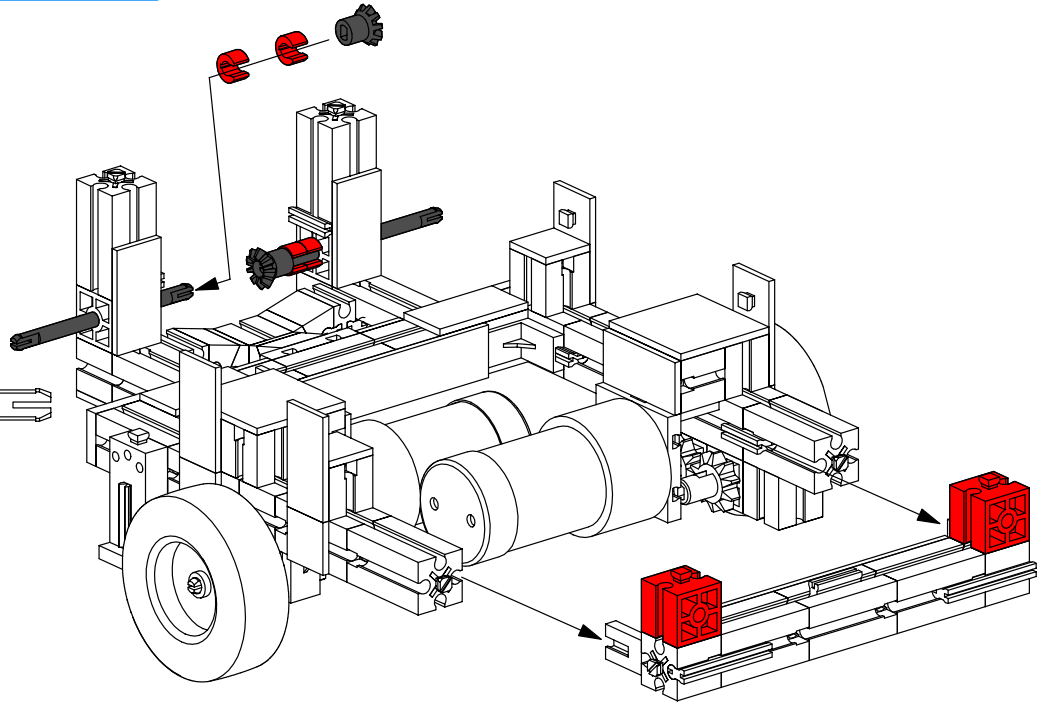
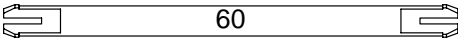
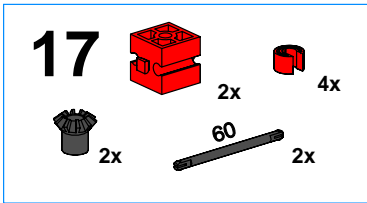
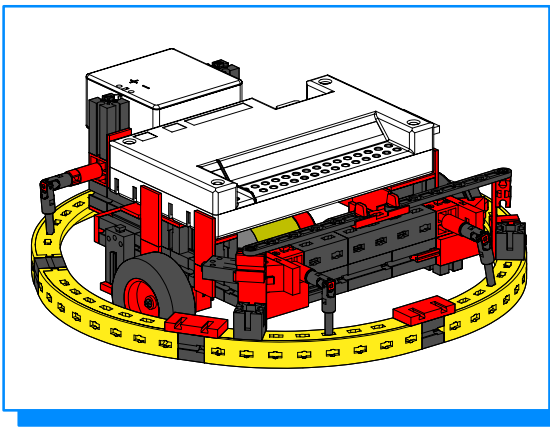

19

- 2x (Red Technic 1x3 Pin)
- 2x (Red Technic 60° Wedge)
- 2x (Black Technic 1x3 Pin)
- 2x (Red Technic Pin)
- 4x (Black Technic Pin)
- 2x (Black Technic Pin)
- 2x (Black Technic Pin 45)

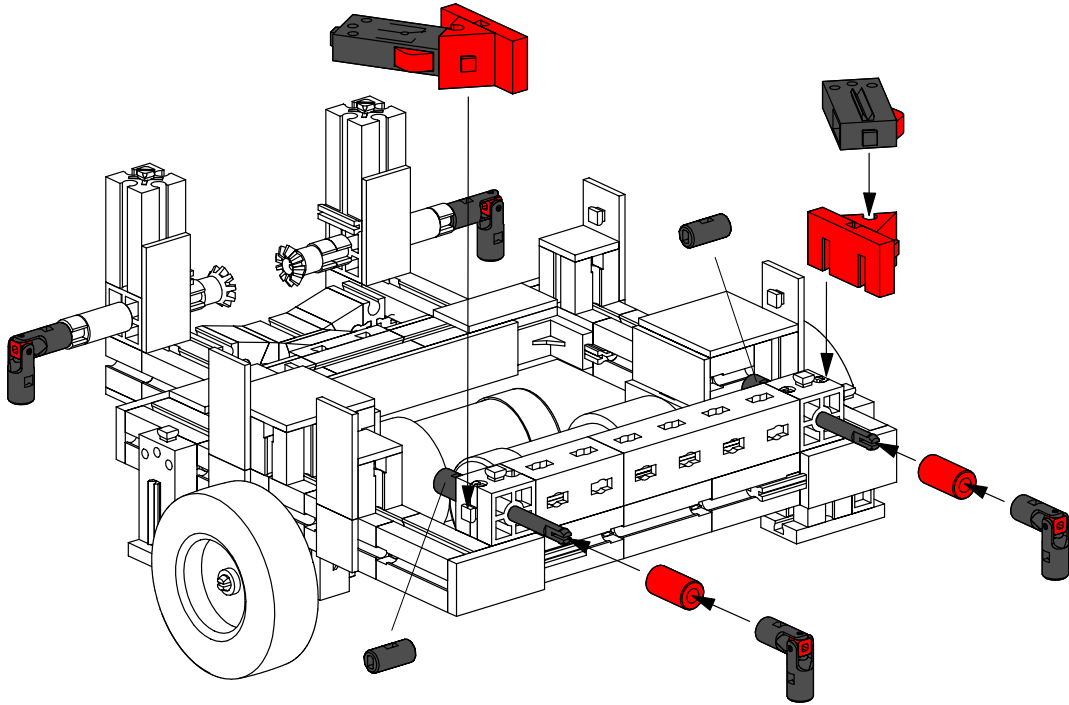
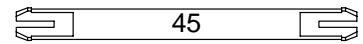

20

- 1x (Black Technic 1x3 Pin)
- 2x (Red Technic 1x3 Pin)
- 1x (Red Technic Pin 15)
- 1x (Black Technic 1x3 Pin)

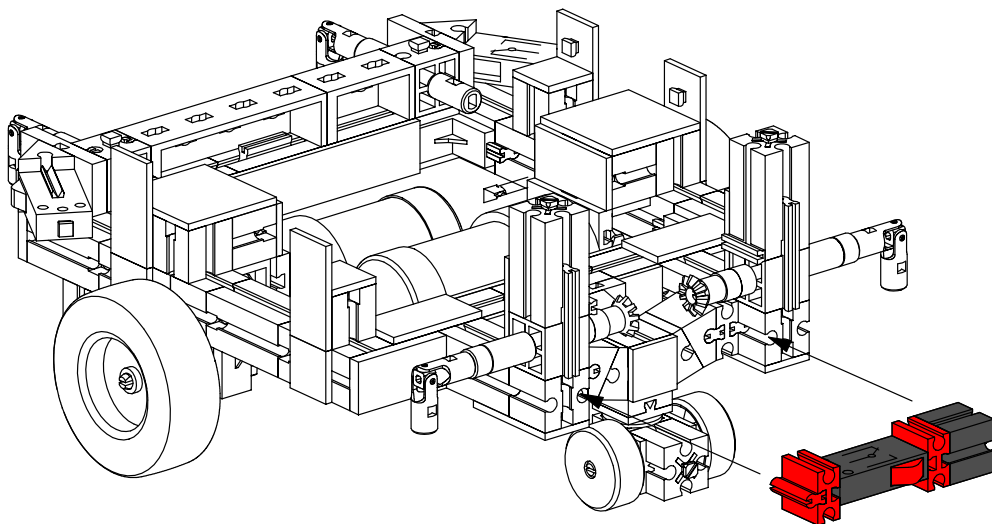

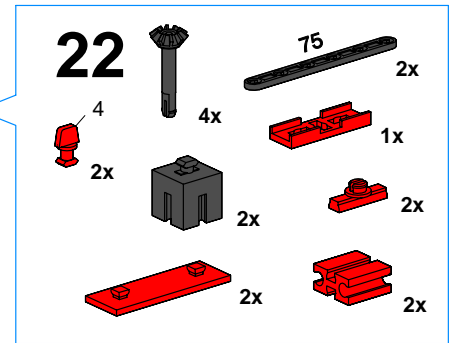
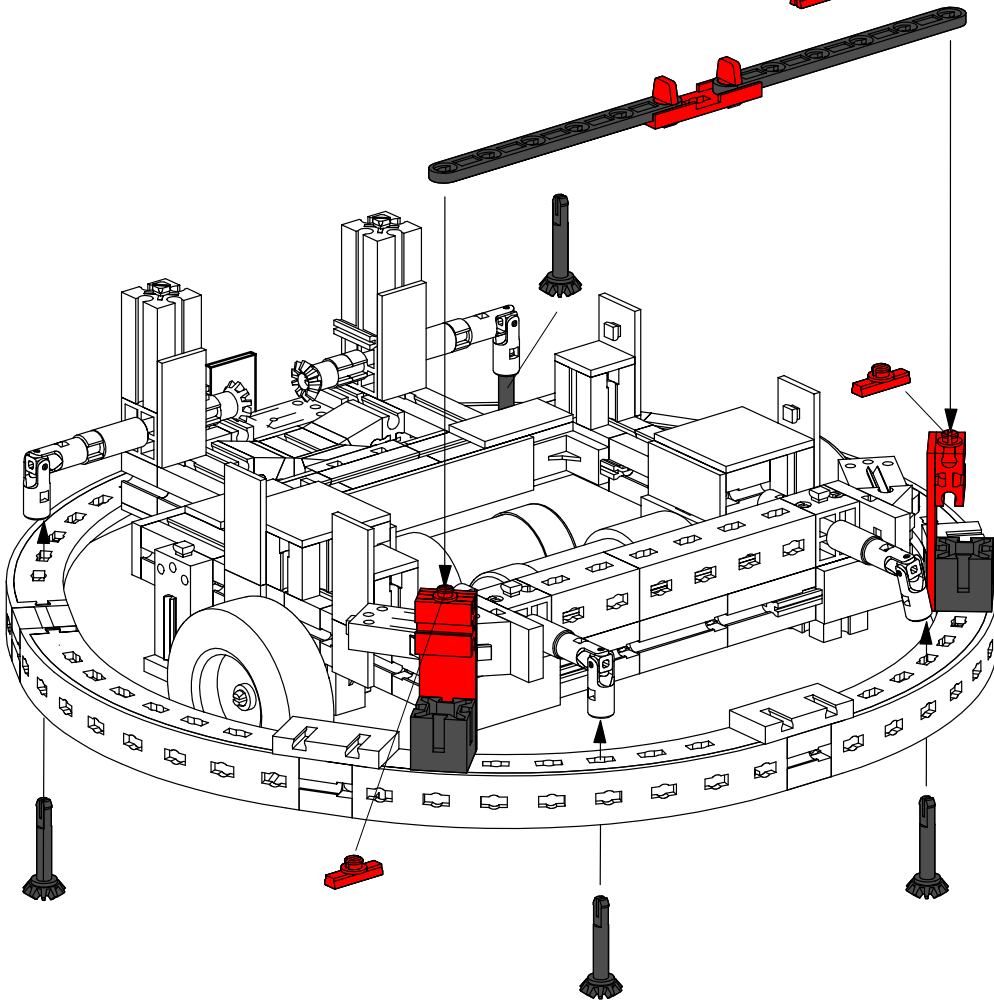
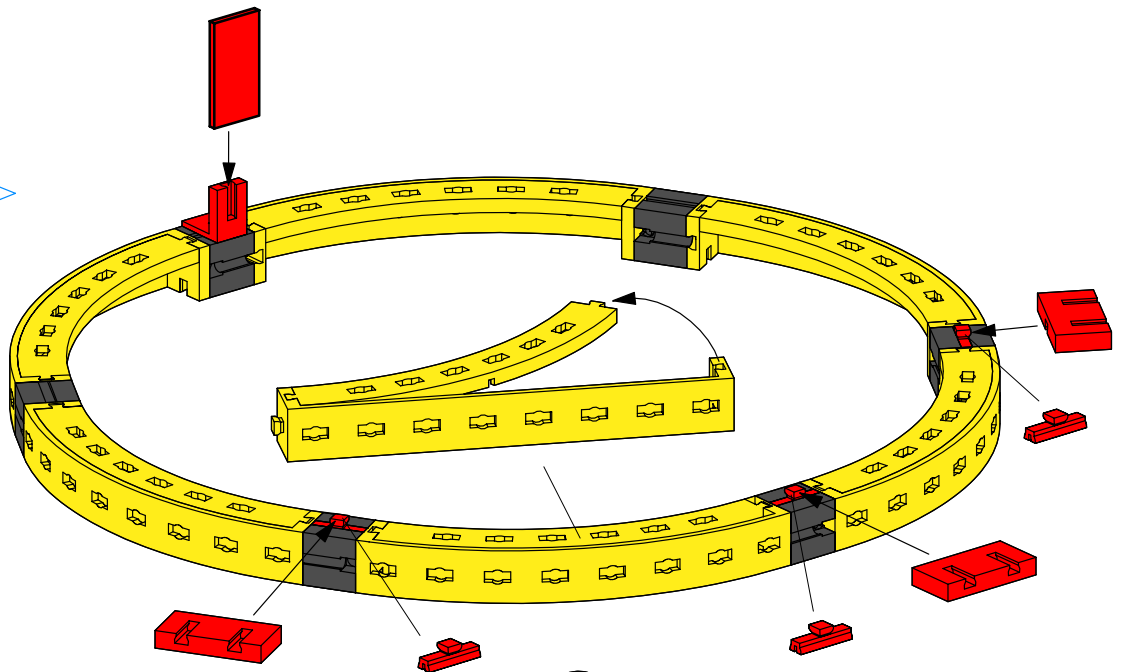
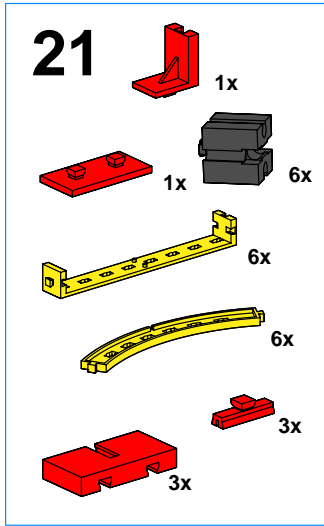

- Intelligent Interface (Art.-Nr. 30402) nicht im Baukasten enthalten
- Intelligent interface (Art. No. 30402) not included in the modular kit
- L'interface intelligente (réf. 30402) n'est pas contenue dans le kit
- Intelligent Interface (art.-nr. 30402) niet in de bouwdoos opgenomen
- El Intelligent Interface (art. n° 30402) no está incluido en el conjunto
- Intelligent Interface (N° de prod. 30402) não contido no sistema de construção por blocos

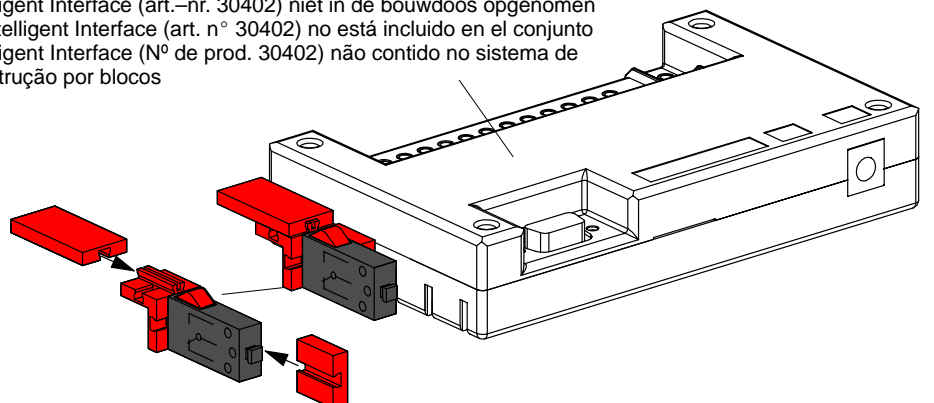
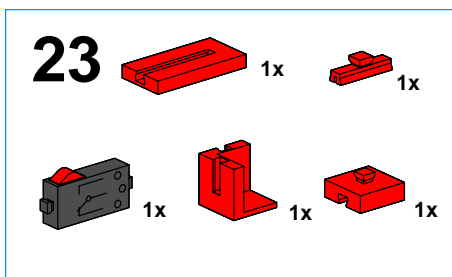

- Accu Set (Art.-Nr. 34969) nicht im Baukasten enthalten
- Accu Set (Art. No. 34969) not included in the modular kit
- Accu Set (réf. 34969) n'est pas contenue dans le kit
- Accu Set (art.-nr. 34969) niet in de bouwdoos opgenomen
- Accu Set (art. n° 34969) no está incluido en el conjunto
- Accu Set (Nº de prod. 34969) não contido no sistema de construção por blocos

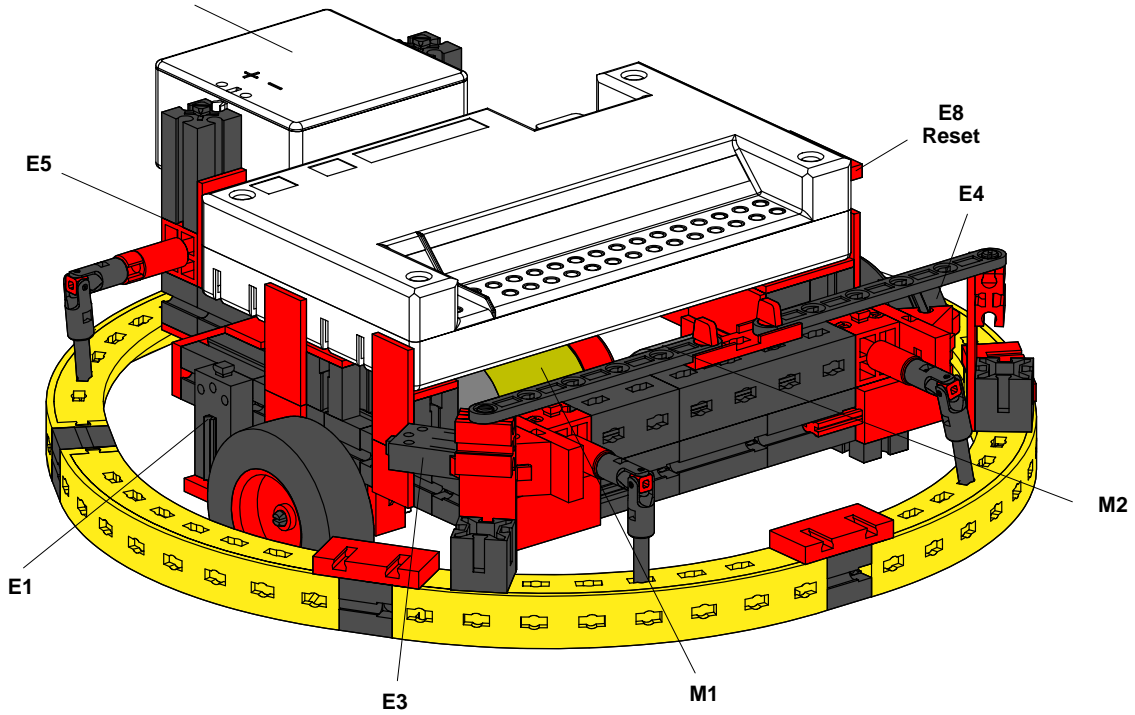

Elektrischer Schaltplan
Circuit diagram
Plan électrique

Schakelschema
Diagrama de circuitos
Plano elétrico de ligação

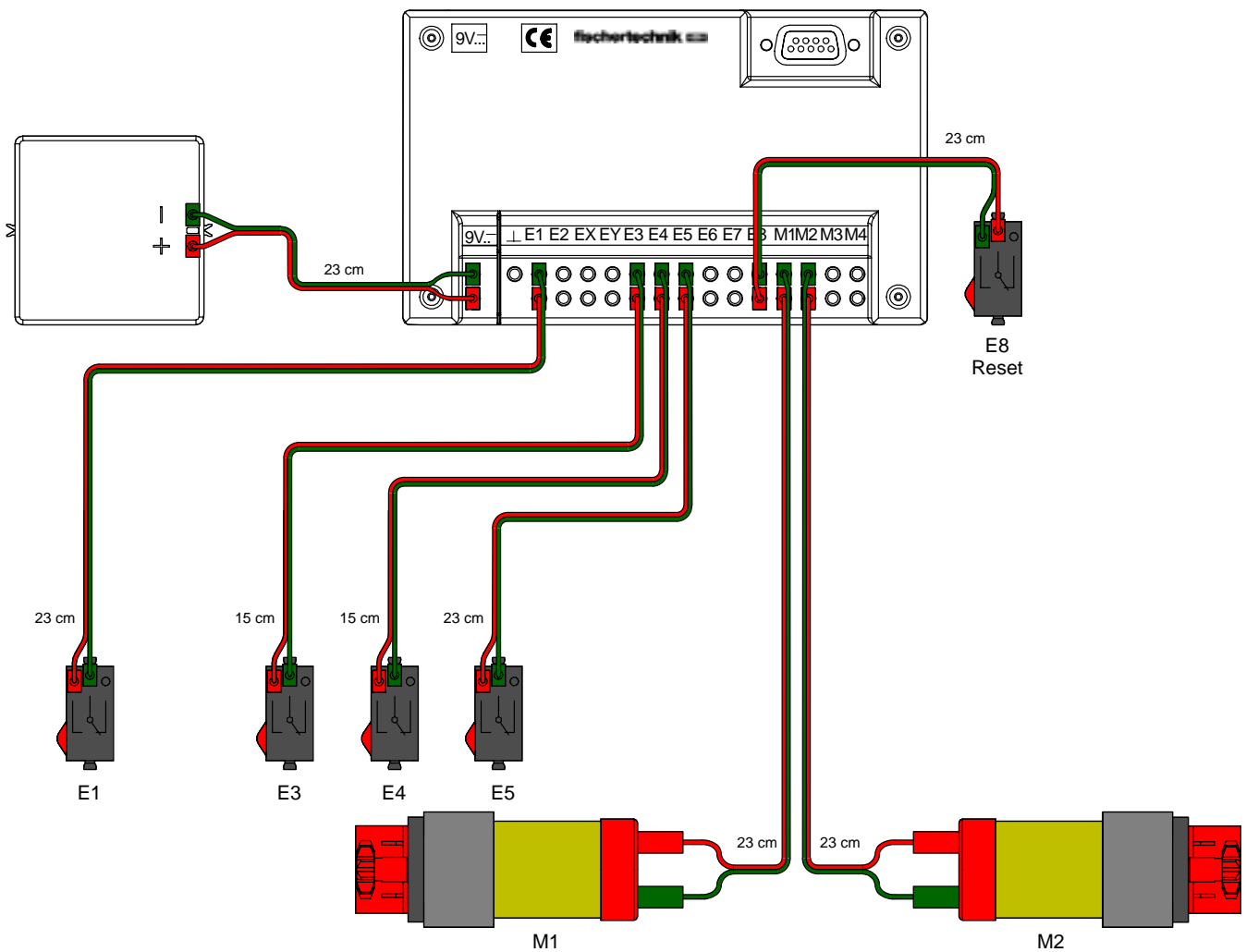

Lichtsucher
Light Finder
Chercheur de lumière

Lichtzoeker
Detector de luz
Identificador de luz

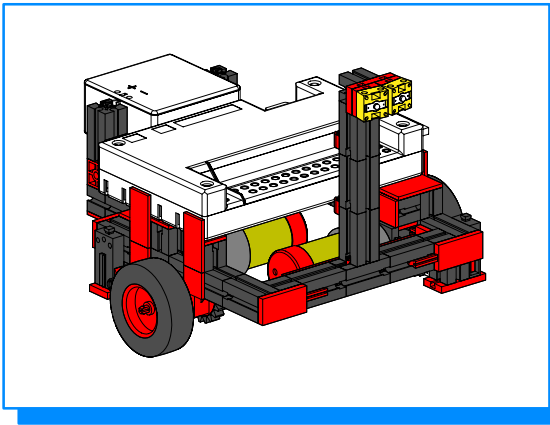

1-16

Seite
Page
Page
Bladzijde
Página
Pagina

4
4
4
4
4
4

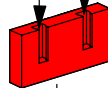
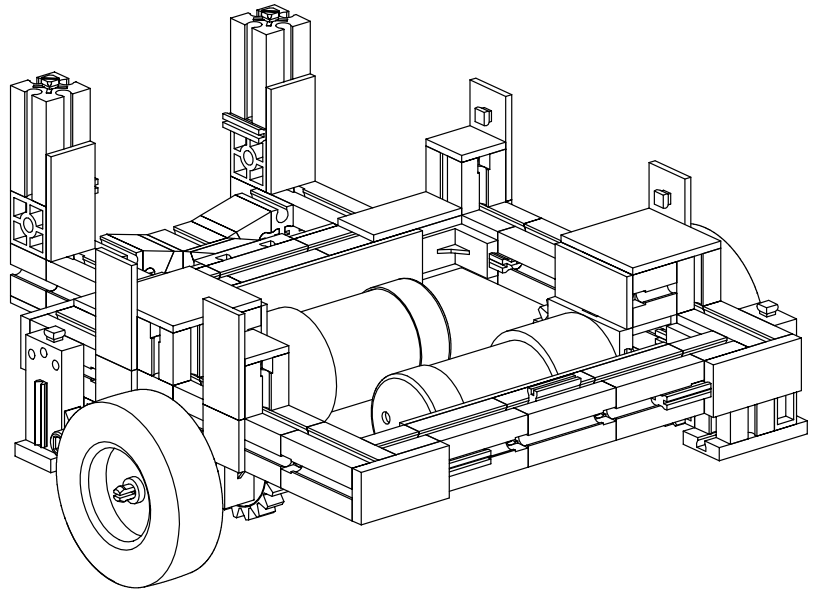

17

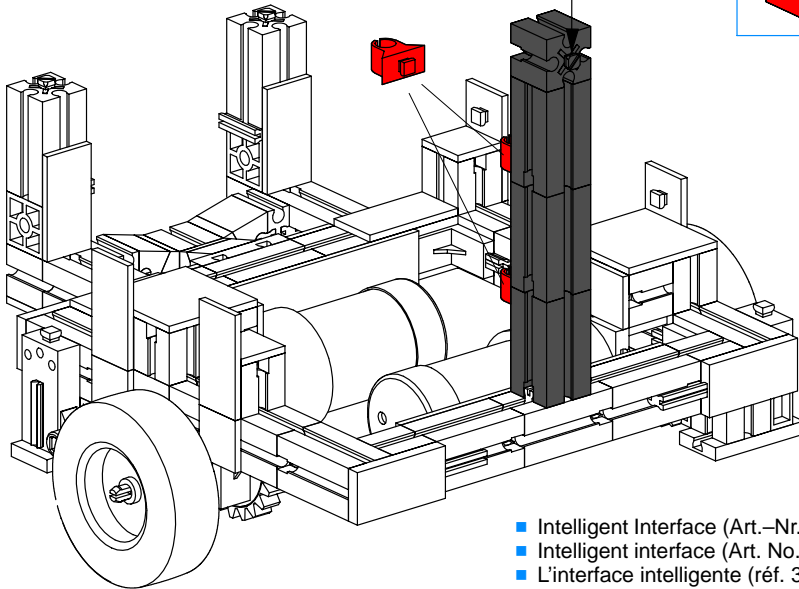
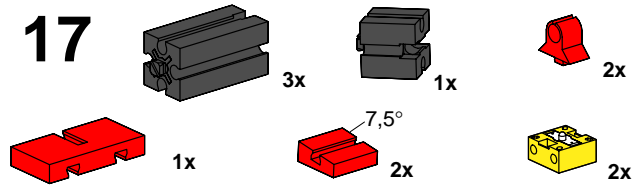

18

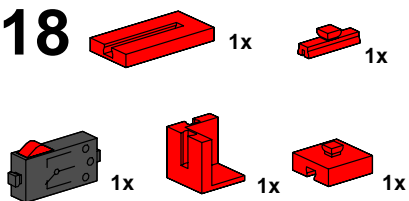

- Intelligent Interface (Art.-Nr. 30402) nicht im Baukasten enthalten
- Intelligent interface (Art. No. 30402) not included in the modular kit
- L'interface intelligente (réf. 30402) n'est pas contenue dans le kit
- Intelligent Interface (art.-nr. 30402) niet in de bouwdoos opgenomen
- El Intelligent Interface (art. n° 30402) no está incluido en el conjunto
- Intelligent Interface (N° de prod. 30402) não contido no sistema de construção por blocos

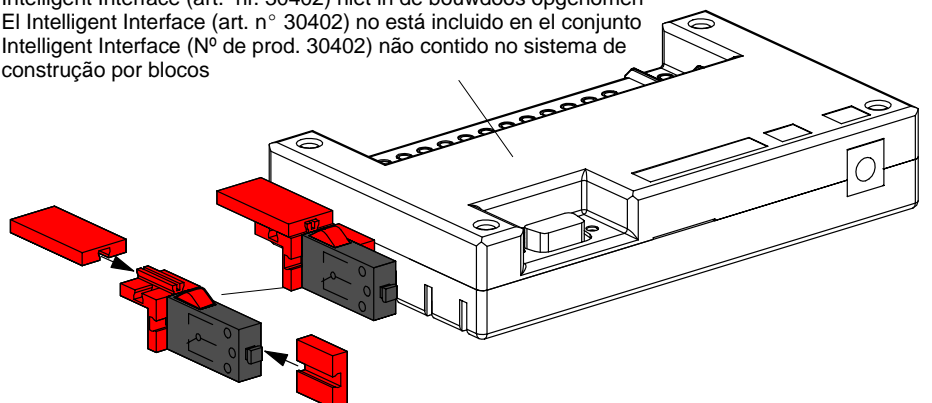

- Accu Set (Art.-Nr. 34969) nicht im Baukasten enthalten
- Accu Set (Art. No. 34969) not included in the modular kit
- Accu Set (réf. 34969) n'est pas contenue dans le kit
- Accu Set (art.-nr. 34969) niet in de bouwdoos opgenomen
- Accu Set (art. n° 34969) no está incluido en el conjunto
- Accu Set (Nº de prod. 34969) não contido no sistema de construção por blocos

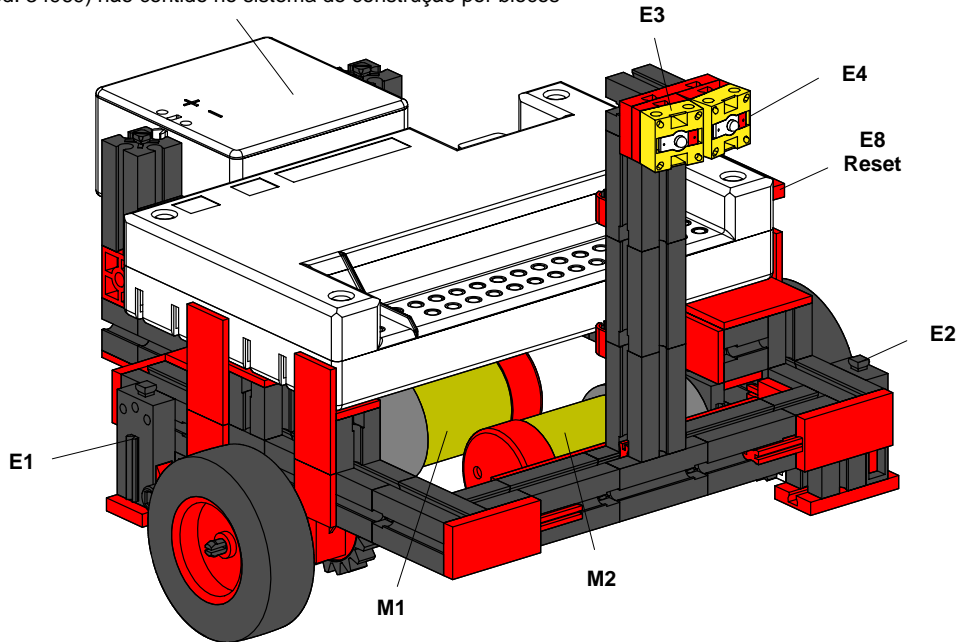

Elektrischer Schaltplan
Circuit diagram
Plan électrique

Schakelschema
Diagrama de circuitos
Plano elétrico de ligação

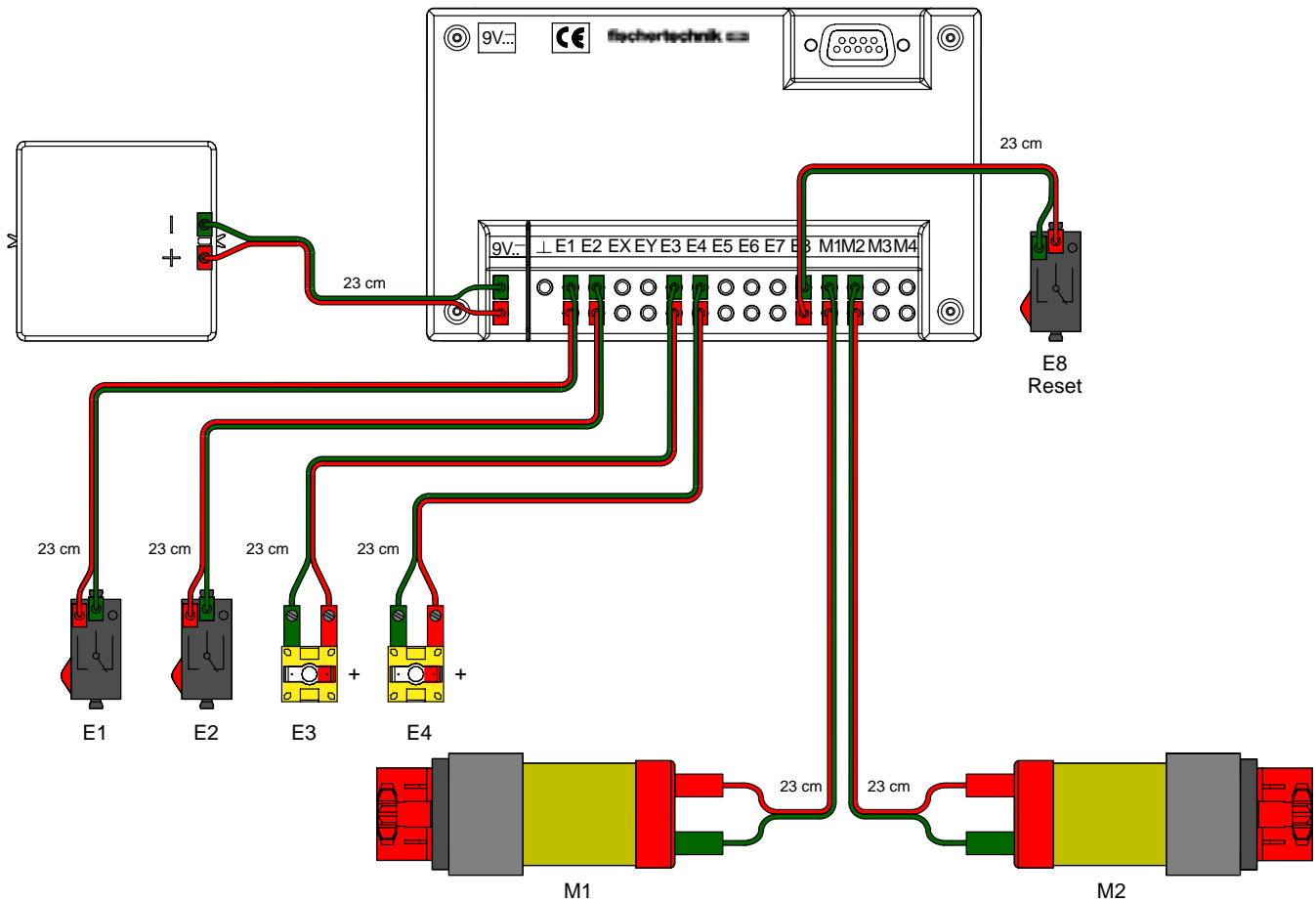

Spurensucher
Tracker
Chercheur de piste

Spoorzoeker
Detector de pistas
Rastreador

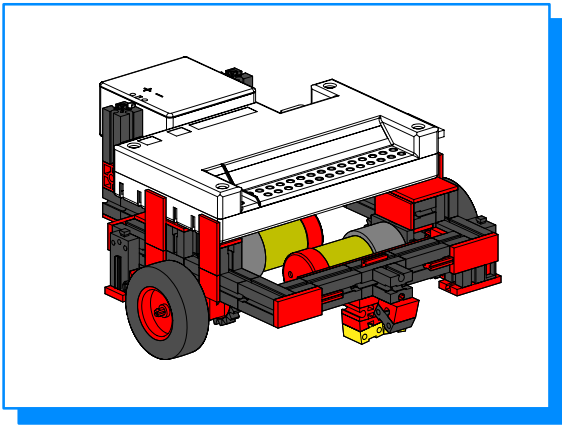



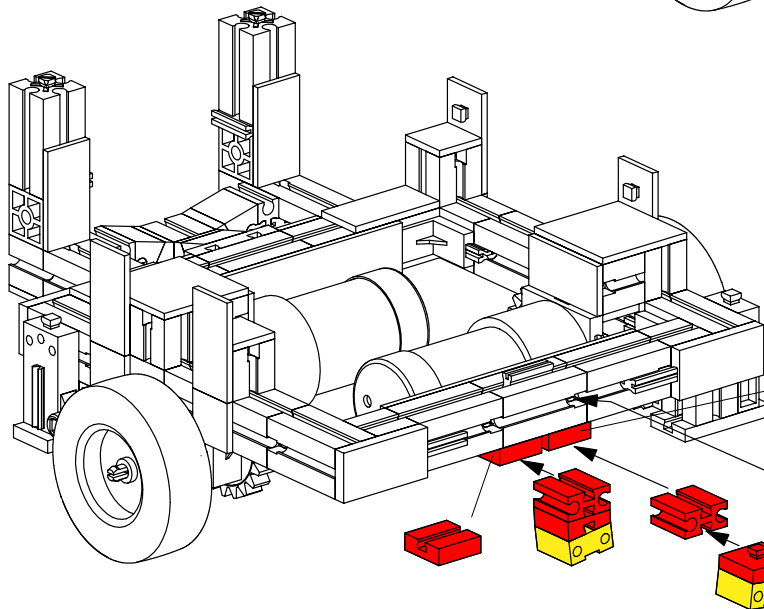
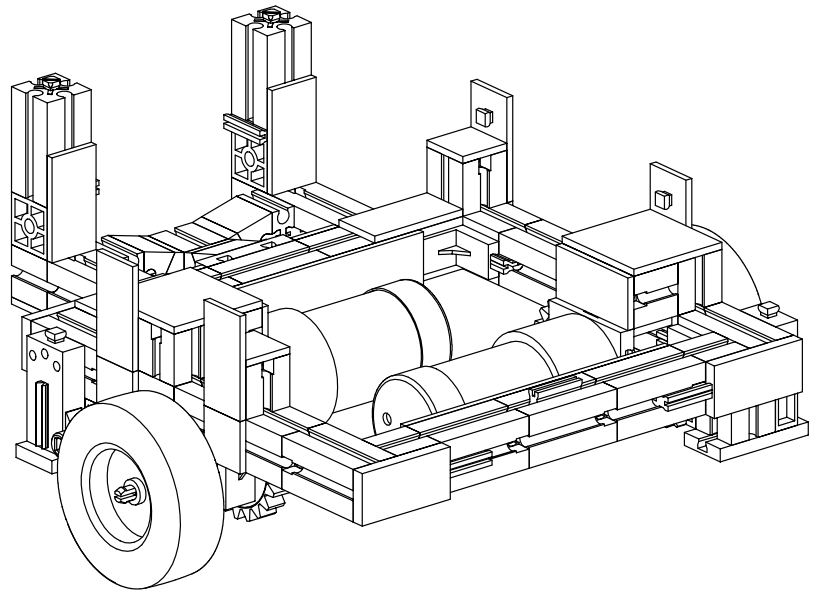

1-16

Seite 4
Page 4
Page 4
Bladzijde 4
Página 4
Pagina 4



17

-  2x
-  2x
-  7.5° 2x
-  2x
-  1x

18

-  30° 1x
-  1x

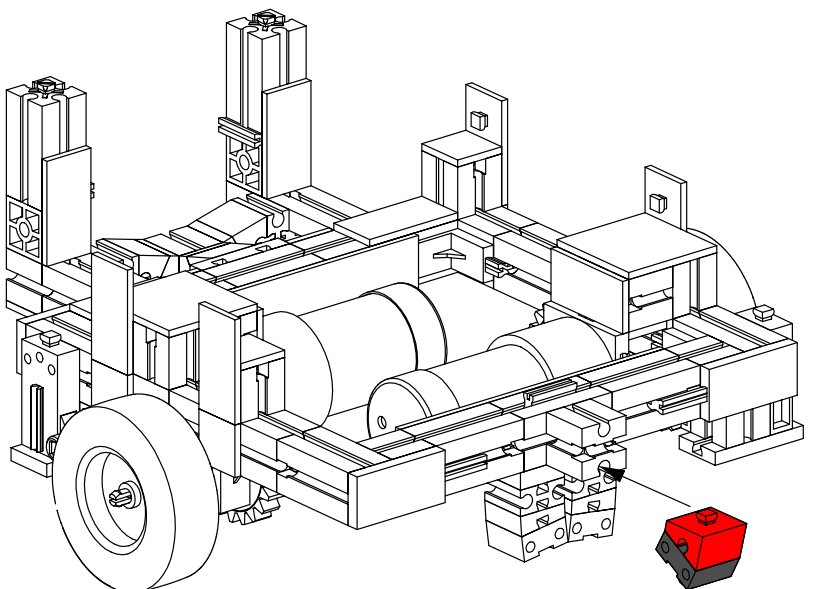

19

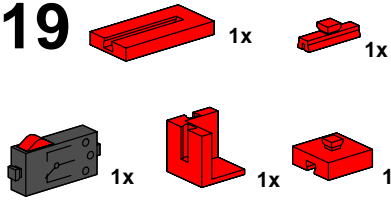

- Intelligent Interface (Art.-Nr. 30402) nicht im Baukasten enthalten
- Intelligent interface (Art. No. 30402) not included in the modular kit
- L'interface intelligente (réf. 30402) n'est pas contenue dans le kit
- Intelligent Interface (art.-nr. 30402) niet in de bouwdoos opgenomen
- El Intelligent Interface (art. n° 30402) no está incluido en el conjunto
- Intelligent Interface (Nº de prod. 30402) não contido no sistema de construção por blocos

- Akku Set (Art.-Nr. 34969) nicht im Baukasten enthalten
- Akku Set (Art. No. 34969) not included in the modular kit
- Akku Set (réf. 34969) n'est pas contenue dans le kit
- Akku Set (art.-nr. 34969) niet in de bouwdoos opgenomen
- Akku Set (art. n° 34969) no está incluido en el conjunto
- Akku Set (Nº de prod. 34969) não contido no sistema de construção por blocos

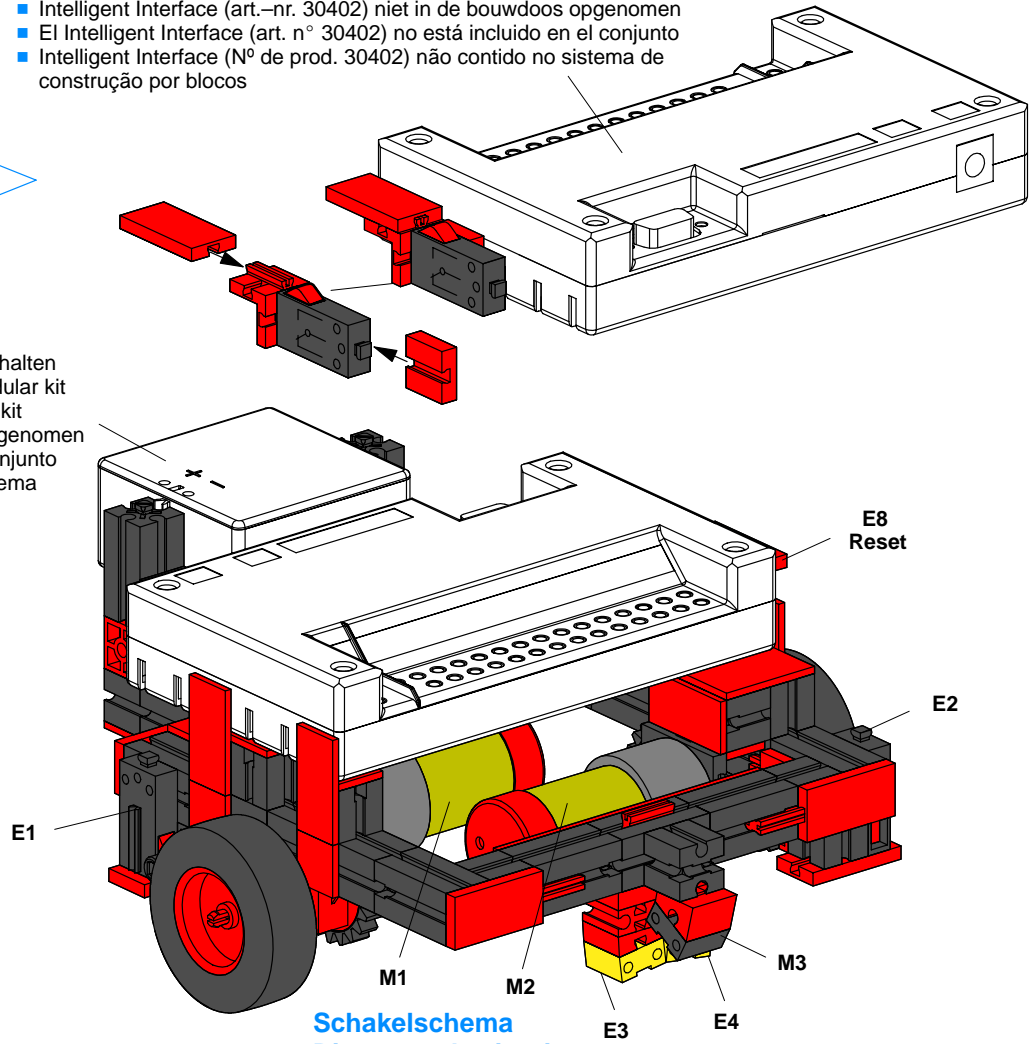

Elektrischer Schaltplan
Circuit diagram
Plan électrique

Schakelschema
Diagrama de circuitos
Plano elétrico de ligação

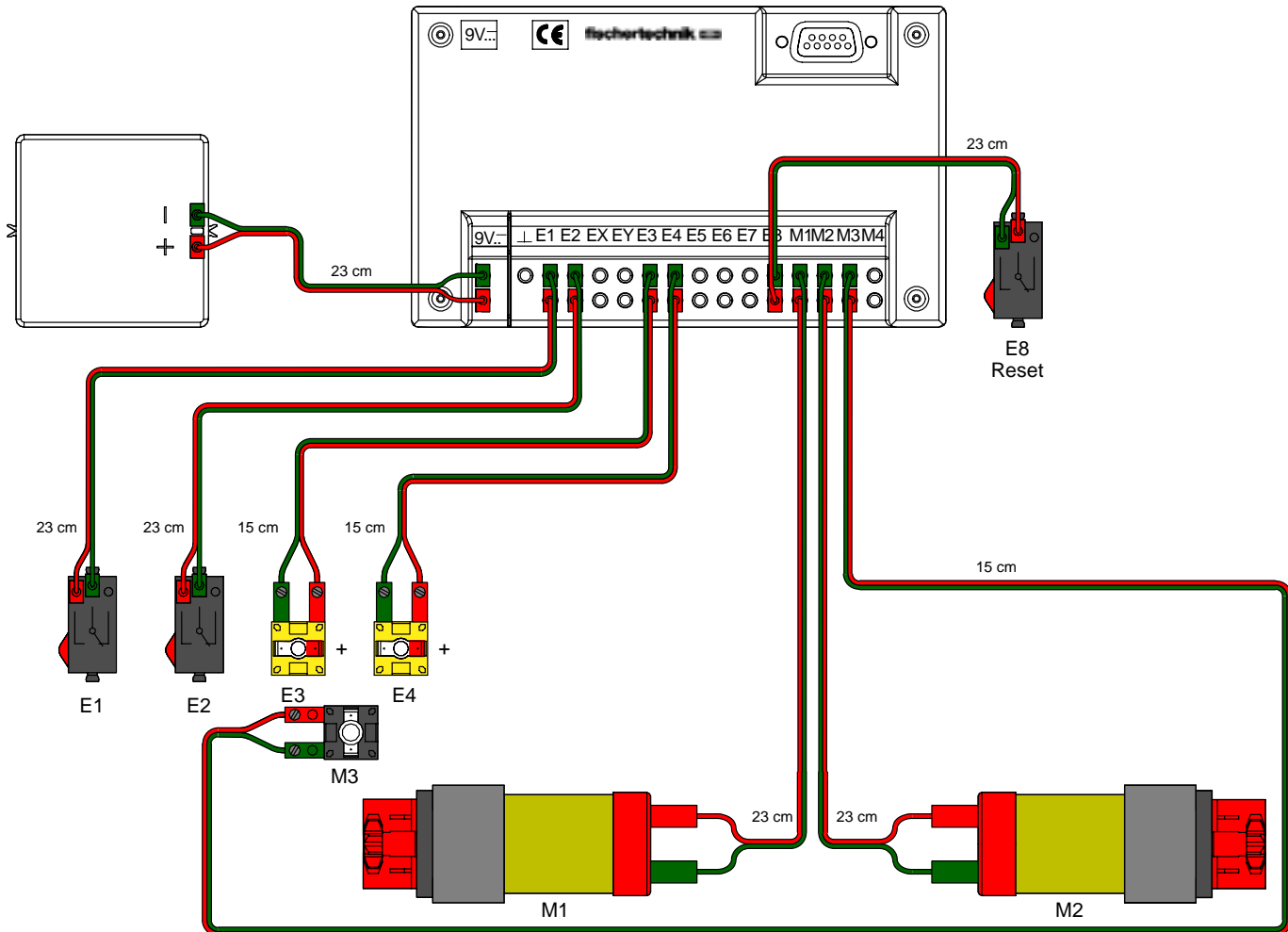

FTS – Fahrerloses Transportsystem
Driverless Transport System
FTS – Système de transport sans chauffeur
FTS – transportsysteem zonder bestuurder
FTS – Sistema de transporte sin conductor
FTS – Sistema de transporte sem condutor

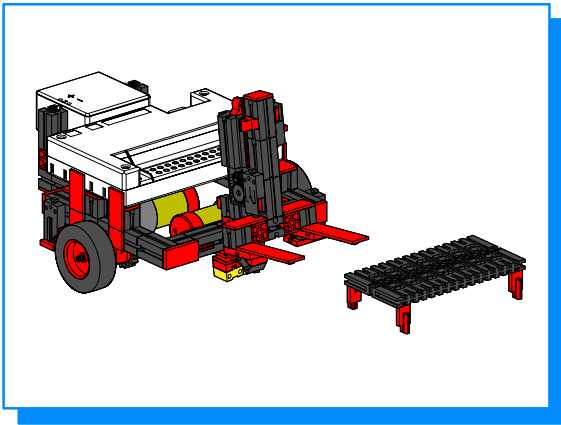

1–16

Seite	4
Page	4
Page	4
Bladzijde	4
Página	4
Pagina	4

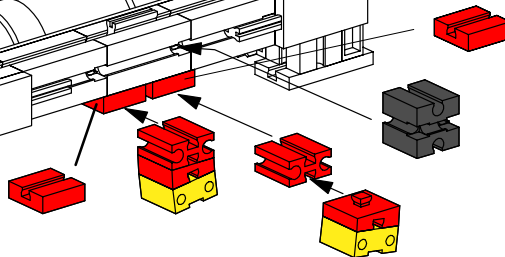
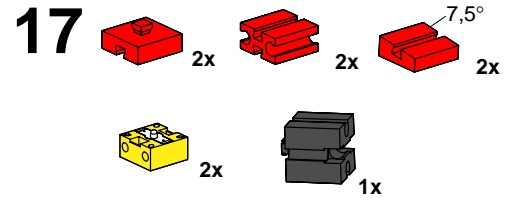
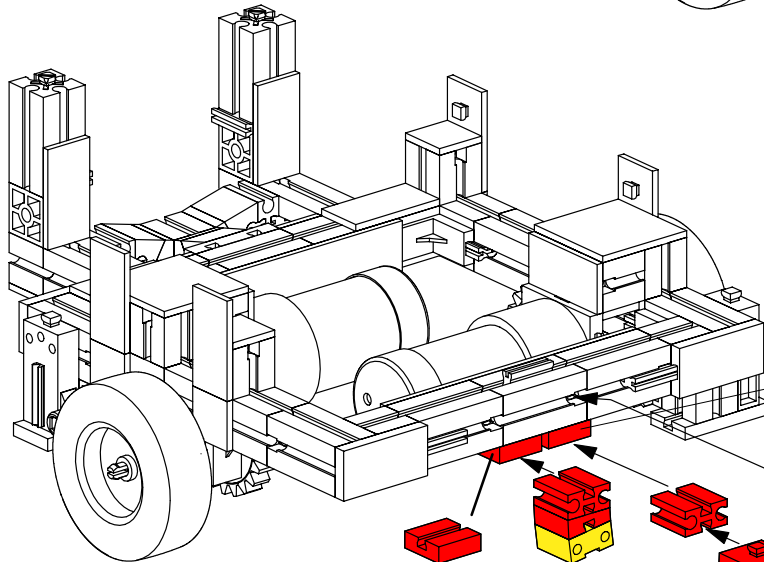
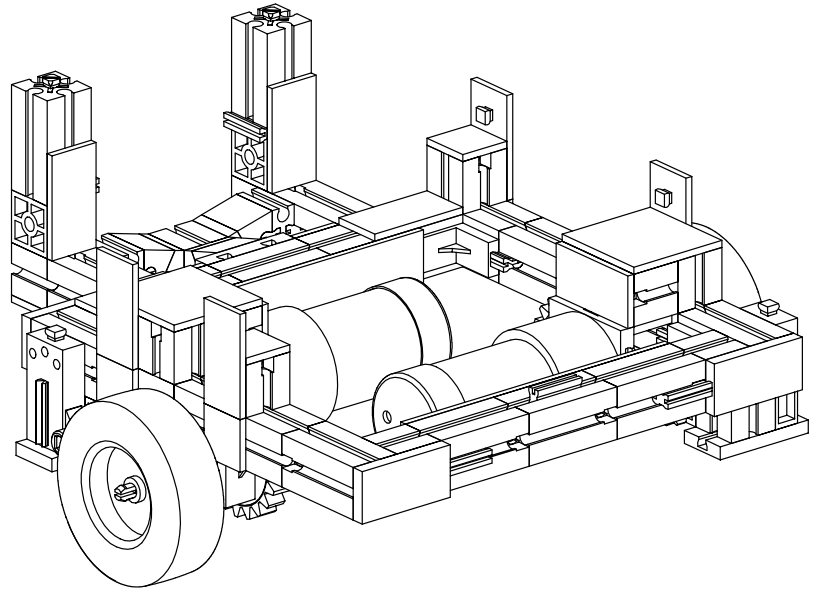

18

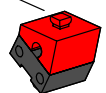
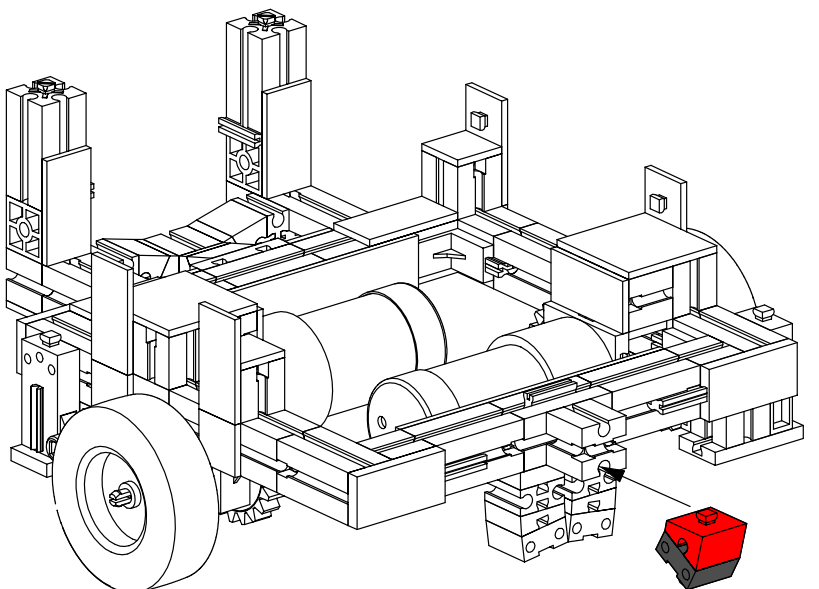
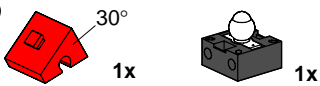

19

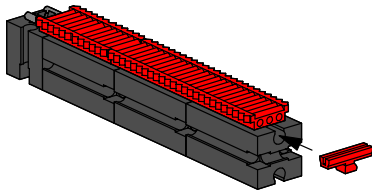
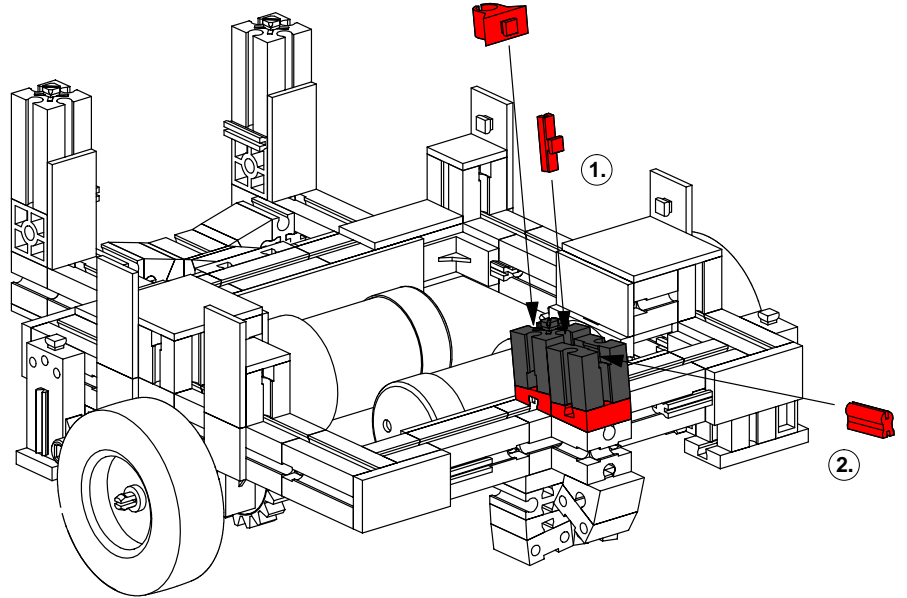
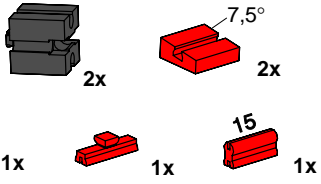

20

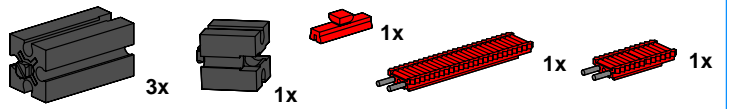

21

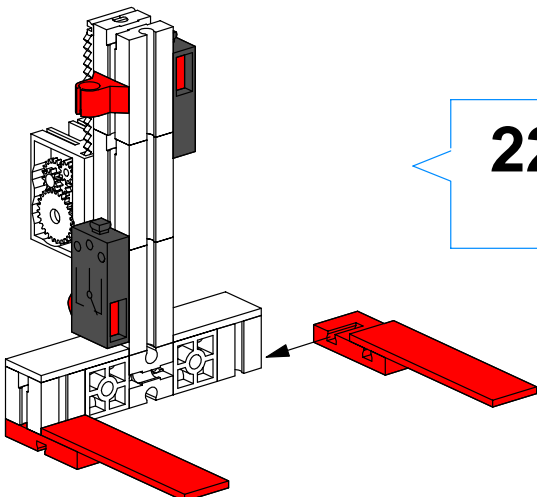
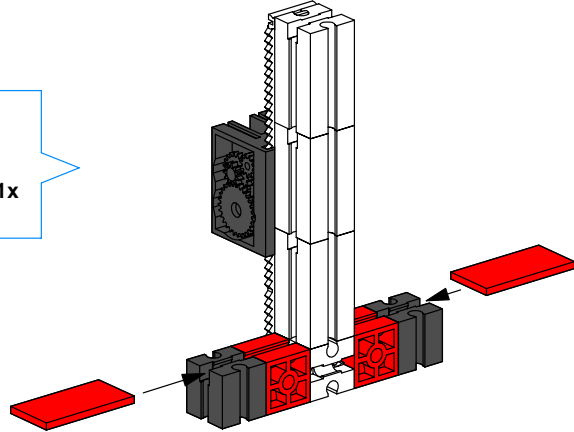
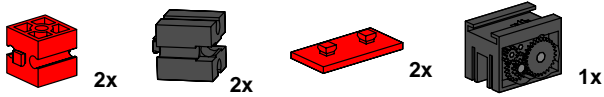

22

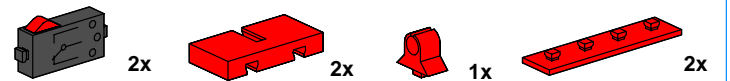

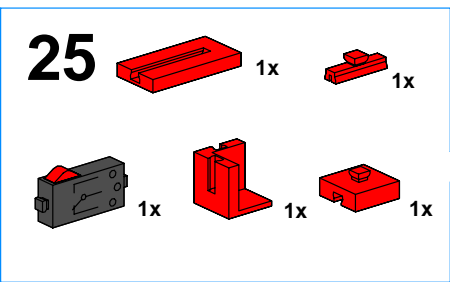
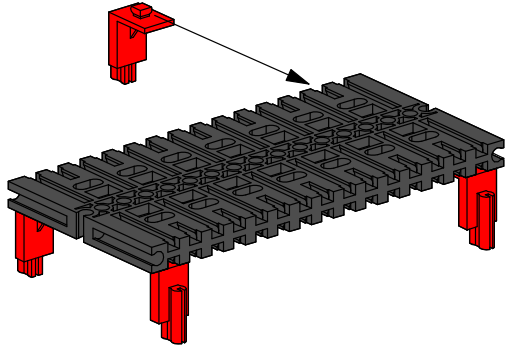
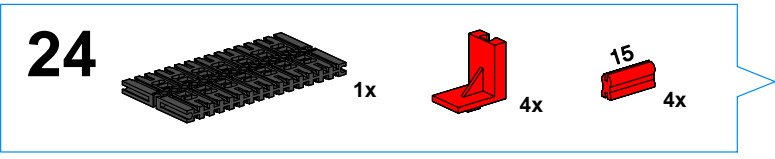
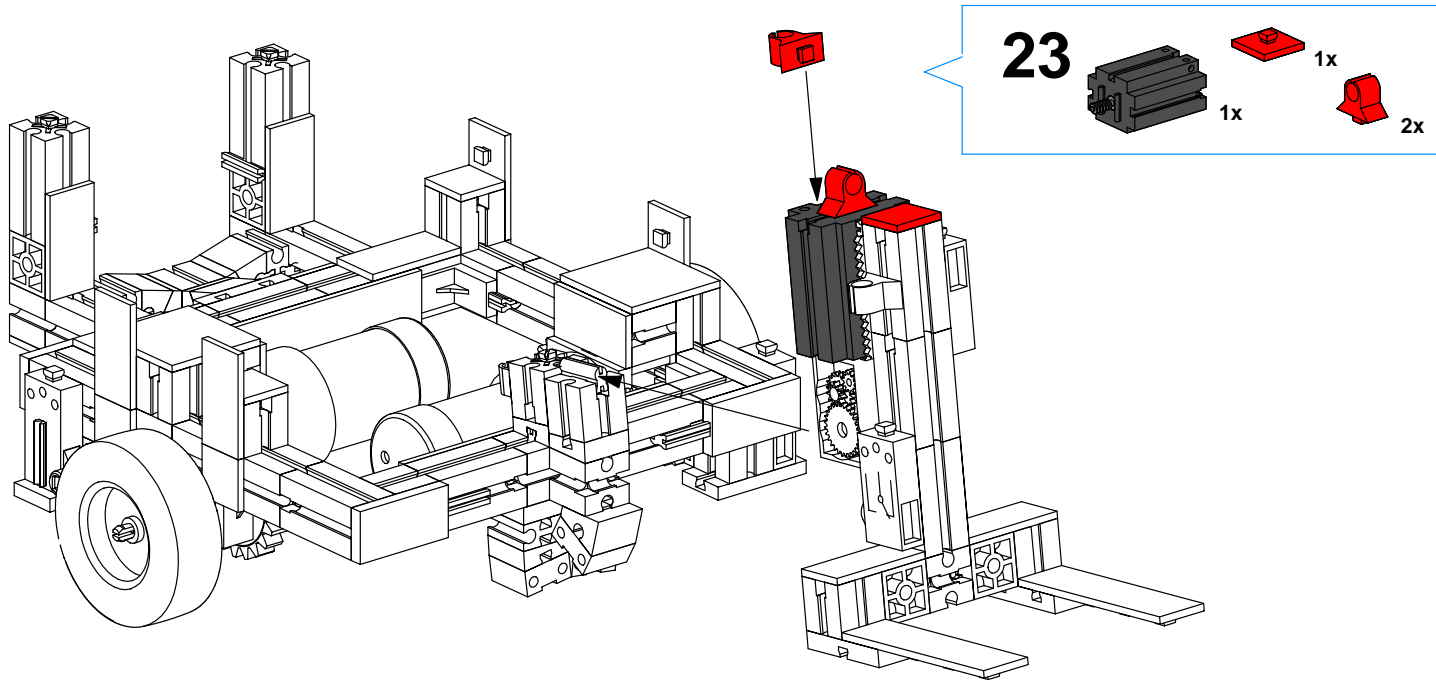

- Intelligent Interface (Art.-Nr. 30402) nicht im Baukasten enthalten
- Intelligent interface (Art. No. 30402) not included in the modular kit
- L'interface intelligente (réf. 30402) n'est pas contenue dans le kit
- Intelligent Interface (art.-nr. 30402) niet in de bouwdoos opgenomen
- El Intelligent Interface (art. n° 30402) no está incluido en el conjunto
- Intelligent Interface (Nº de prod. 30402) não contido no sistema de construção por blocos

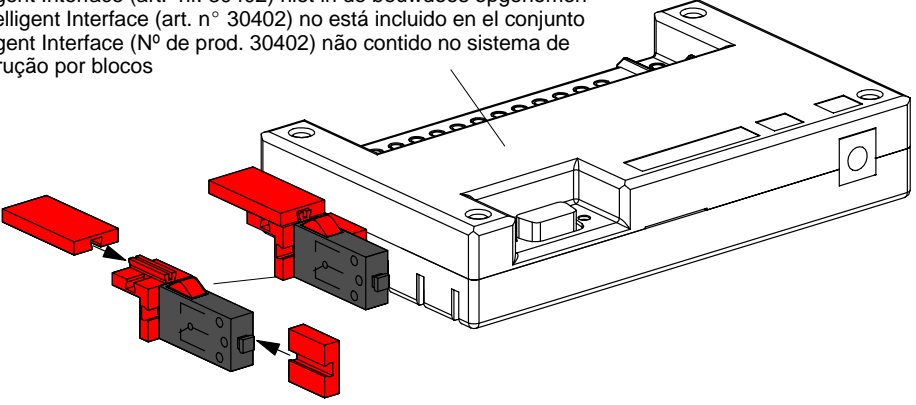

- Accu Set (Art.-Nr. 34969) nicht im Baukasten enthalten
- Accu Set (Art. No. 34969) not included in the modular kit
- Accu Set (réf. 34969) n'est pas contenue dans le kit
- Accu Set (art.-nr. 34969) niet in de bouwdoos opgenomen
- Accu Set (art. n° 34969) no está incluido en el conjunto
- Accu Set (N° de prod. 34969) não contido no sistema de construção por blocos

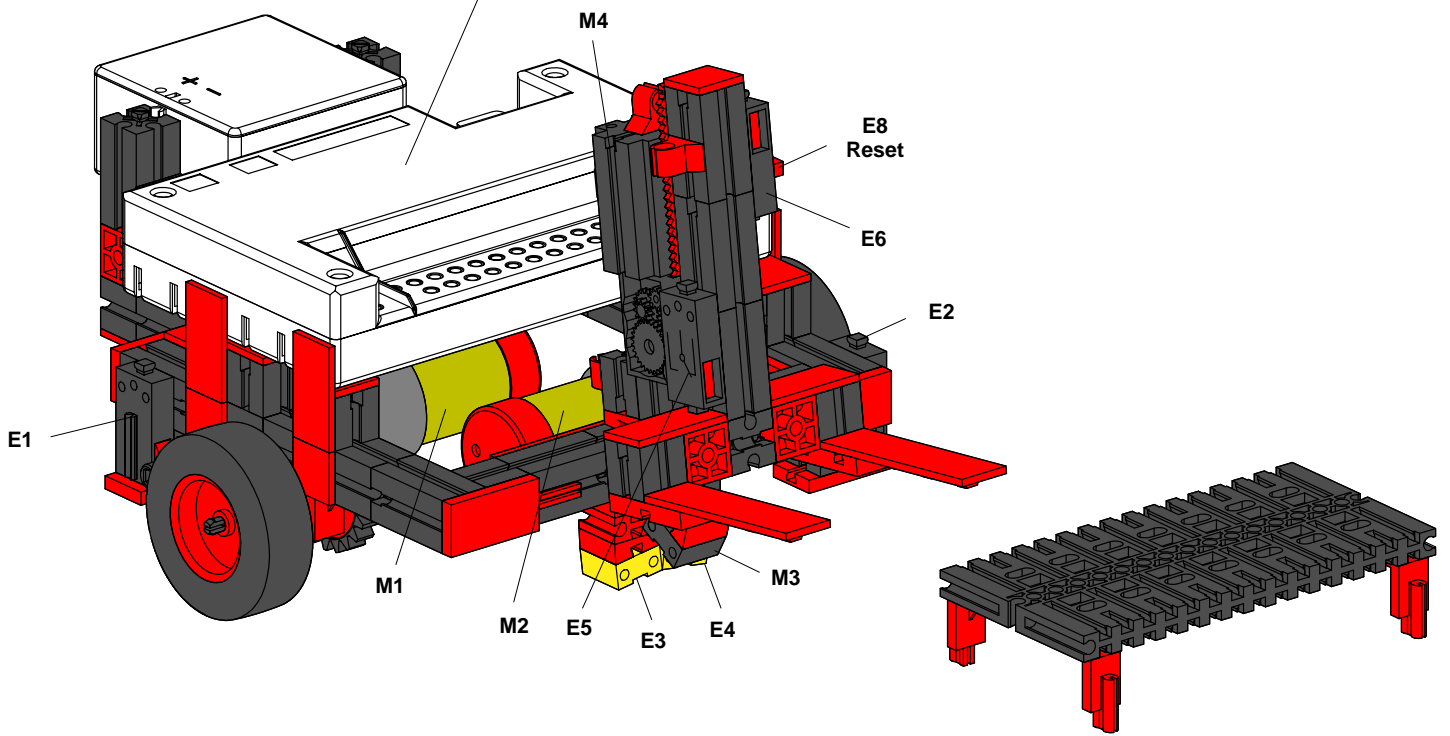

Elektrischer Schaltplan
Circuit diagram
Plan électrique

Schakelschema
Diagrama de circuitos
Plano elétrico de ligação

